

Wheeled Excavator

A 918 Compact

Litronic®

Generation

6

Operating Weight

17,500 – 19,600 kg

Engine

115 kW / 156 HP

Stage V

Bucket Capacity

0.17 – 1.05 m³



LIEBHERR

Performance

Compact, Flexible – Perfect Combination
for Maximum Performance

Economy

A Sound Investment – Optimum Economy
and Environmentally Friendly

Operating Weight

17,500 – 19,600 kg

Engine

115 kW/156 HP

Stage V

Bucket Capacity

0.17 – 1.05 m³



Reliability

Competence, Consistency, Innovation –
Proven Experience

Comfort

Ergonomic Excellence – Superior Cabin
Design for Operator Comfort and Wellbeing

Maintainability

Service Every Step of the Way –
Simple, Fast and Reliable



Performance



Compact, Flexible – Perfect Combination for Maximum Performance

Liebherr compact wheeled excavators are used on building sites all over the world, where they embody force and speed combined with compact dimensions. Using them, machine operators achieve impressive levels of performance, day in and day out. Whether on inner city building sites, in roadway construction, classic earthmoving or for digging trenches and laying pipes, more can be achieved faster with Liebherr compact wheeled excavators.

Maximum Performance

Lifting More

The intelligent structure of the uppercarriage and the separate mounting of the hoist cylinders permit a superior lift capacity – and this with a tail swing radius of only 1.85 m. As a result, the A 918 Compact Litronic combines the flexible application possibilities of a compact wheeled excavator with the performance of a standard wheeled excavator. Performance and flexibility for every building site.

Being Faster

The A 918 Compact Litronic enables a high working speed, even when movements of attachment are performed in parallel. Excavating, backfilling and profiling tasks can be completed faster, new tasks can be started sooner. The speed of the machine can be adjusted easily using the MODE switch for load lifting work or grading work.

Joystick Steering

With the optional joystick steering, the driver can steer the wheeled excavator proportionally using the mini joystick. In this way, working and driving movements can be performed at the same time without having to change controls. More efficient operation for even greater productivity.



Joystick with Proportional Control

- Good functionality with streamlined, ergonomic design
- 4-way mini-joystick enables versatile possibilities of control without having to encompass, for example steering, outriggers or working tools
- Two buttons and a rocker switch also increase the number of functions

Digging Force

- High digging and breakout force in the field
- Continuously high digging performance even in tough ground
- More digging force for faster results

Liebherr Tyres

- Twin tyres without intermediate ring with offset lugs
- Increased stability during work and less vibration when driving thanks to higher tyre inflation pressure
- Better self-cleaning properties – even after a few metres – prevents soiling of the track surface
- Larger contact area for less ground pressure and higher traction on soft ground

Precise Work

Working with Precision

The standard joysticks with proportional controls and also the extraordinary sensitivity of the hydraulic system enable precision work at high speeds and parallel movements. This means the machine operator can carry out the most challenging tasks in a short time, not only at reduced speed but also with maximum performance output from the machine.

Automatic Digging Brake

The automatic digging brake ensures that manual actuation of the brake pedal is no longer required, thus leading to easier operation of the machine. When the accelerator pedal is in a neutral position and the machine is stationary, the digging brake engages automatically. This results in faster work processes and enhanced safety for man and machine, particularly during operation with frequent relocation of the excavator. Furthermore, the automatic digging brake can be linked with the automatic swing axle lock. When the machine is deployed and working, the swing axle locks automatically and thereby provides optimum stability.

Economy



A Sound Investment – Optimum Economy and Environmentally Friendly

Liebherr compact wheeled excavators are machines that combine high productivity and compact flexibility with excellent levels of economy – and all this comes as standard from the factory. On request, the efficiency of each wheeled excavator can be boosted further with a Liebherr productive bucket, a fuel-saving Liebherr hydraulic oil or a Liebherr quick coupling system, all of which provide more return from each operating hour.

Maximum Efficiency

Low-maintenance SCRT System

To comply with emissions standard V Liebherr employs the latest SCRT system which consists of an SCR catalyst and a standard particulate filter. The low fuel burn of these machines results in reduced emissions and ensures that Liebherr wheeled excavators are environmentally friendly.

Engine Idling and Engine Shut-down

The standard automatic idling function reduces the engine speed to idle as soon as the operator takes his hand from the joystick so that no hydraulic function is activated. Proximity sensors in the joystick levers restore the original engine speed as soon as the operator's hand is moved towards the lever again. This ensures that the set engine speed is available immediately. The result is a combination of fuel saving and reduced noise levels. Operating costs can be reduced even further with the optional automatic engine shut-down function.

Increased Productivity

Liebherr Working Tools and LIKUFIX

To boost the productivity of its construction machines, Liebherr offers a broad range of working tools for different fields of application. Furthermore, the hydraulic excavators can also be equipped with the Liebherr LIKUFIX hydraulic quick coupling system. The combination of a hydraulic Liebherr quick coupling system with the LIKUFIX coupling block permits fast safe changing of mechanical and hydraulic working tools from the operator's cabin. This boosts productivity on average by 30%.

Efficient Management

LIDAT, Liebherr's own data transmission and positioning system, facilitates efficient management, monitoring and control of the entire fleet in terms of machinery data recording, data analysis, fleet management and service. All of the important machinery data can be viewed at any time on a web browser. LIDAT provides you comprehensive work deployment documentation, greater availability thanks to shorter downtimes, faster support from the manufacturer, quicker detection of strain/overload and subsequently a longer service life of the machine as well as greater planning efficiency.

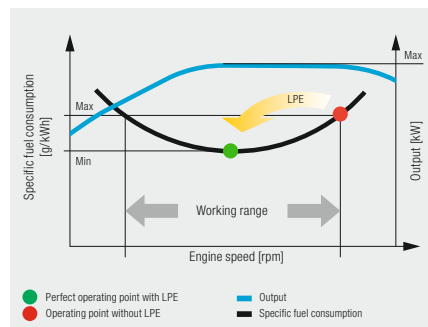

Travel Drive

- High tractive force for fast acceleration on level ground and high end speed on gradients
- Reduces unproductive travel time between tasks and on the building site
- Faster on site – More productive

Low Fuel Consumption Thanks to Intelligent Machine Control

- Liebherr-Power Efficiency (LPE) optimises the interaction of the drive components in terms of efficiency
- LPE enables machine operation in the area of the lowest specific fuel use for less consumption and greater efficiency with the same performance

Liebherr Quick Coupling System LIKUFIX

- Faster and safer changing of mechanical and hydraulic working tools from the operator's cabin
- Machine utilization increased to up to 90% thanks to extended deployment options
- Visual and acoustic check of correct locking position of tool at quick coupling system by two proximity sensors

Reliability



Competence, Consistency, Innovation – Proven Experience

Reliability offers safety. Safety that significantly influences the success of a project. Whatever the weather, Liebherr stands for safety – with reliable construction machines and customer-oriented sales and service partners. This means a Liebherr construction machine is exactly what it should be: an investment that pays off.

High Machine Availability

Quality and Competence

Our product experience, our understanding of technical design and feedback from customers, sales and service form the basis for the use of pioneering ideas and have always been an integral part of our recipe for success. Key components such as the diesel engine, electronic components, slewing ring, slewing drive and hydraulic cylinders are developed and manufactured in-house. Our great production depth guarantees the highest possible quality and allows the components to be coordinated perfectly.

Reduced Vibrations

The driving oscillation dampers comprise pressure accumulators that act as “shock absorbers” on the lift cylinders to ensure that vibrations from the equipment are not transferred to the uppercarriage. The damping function reduces the mechanical load on the steel structure, which in turn results in a longer service life of the components.



QPDM – Quality and Process Data Management

- QPDM allows production data to be logged, documented and evaluated
- Automation of documentation and test specifications
- Ability to handle large quantities and maintain uniform high quality

Greater Safety

Safety

In addition to the performance and economy of a wheeled excavator, the other main focus is on the safety of personnel and the machine. A wide range of equipment such as pipe fracture safety devices on lifting and stick cylinders, load holding valves on outriggers, lift limitation in height, overload warning device, roll-over protection system (ROPS) and the emergency exit through the rear window deliver maximum safety for every job.

Excellent All-round Vision

The large areas of glass and the rear and side area monitoring systems provide the operator with an excellent view of his working area and the zone around the machine. This perfect view enhances the operator’s safety and ensures that in turn he can handle the machine safely at all times.

Robust Construction

All the steel components are designed and manufactured by Liebherr. High strength steel sheets designed to withstand the harshest requirements guarantee high torsion resistance and excellent absorption of forces to ensure a long service life.



Less is More

- Extended range of possible applications due to a short tail swing radius of only 1.85 m
- Greater safety for man and machine
- Liebherr compact wheeled excavators: short and safe



Bright and Durable

- Numerous work lamps light up the working area perfectly and, in doing so, provide better visibility and even greater safety for man and machine
- The standard LED tail lights are not just nice looking but also have high luminosity and an extremely long service life

Comfort



Ergonomic Excellence – Superior Cabin Design for Operator Comfort and Wellbeing

The modern Liebherr operator's cab is the largest in this machine class, and offers the best conditions for healthy, focussed and productive working. Standard features include an air-sprung operator seat with seat heating, automatic air conditioning and the ergonomically arranged control elements with touchscreen indicating unit. An example of the extensive safety equipment is the roll-over protection system (ROPS) for the cab fitted as standard according to ISO 12117-2 as well as the standard windows made from impact-resistant laminated safety glass.

First-class Cab

Automatic Air Conditioning

The automatic air conditioning offers convincingly intuitive operation. Temperature, blower setting and the various air nozzles in the head, chest and foot areas are set using the touch screen on the indicating unit. The defrost/defog one-button function clears fogged up windows in the shortest possible time. The filter for the cab air can be changed easily and conveniently from the outside.

Operator Seats

The Standard, Comfort and Premium operator's seat versions deliver maximum comfort. Even the standard operator seat offers an extensive range of features such as air suspension, seat heating, headrest, lumbar support and many more.

Low Noise Levels

The use of viscoelastic mounts, good insulation and lownoise diesel engines from Liebherr minimises noise emissions and vibrations. The noise levels are just 71 dB(A) in the operator's cab and 100 dB(A) outside.



Refuelling

- Using the optional refuelling pump, the machine can be refuelled directly from a fuel container
- The tank hose integrated in the service door and the automatic shut-off when the tank is full offer greater convenience and short replenishment times
- Topping up – simple, quick and safe

Maximum Safety

- More convenient and safer entry and exit in and out of the cab thanks to added width from the folding arm console
- Three entry steps with standard anti-slip galvanised plates provide a boost to safety

Intuitive Operation

- Display of the machine data and camera image on the 7-inch indicating unit with touch screen and direct access via menu bar
- 20 user-programmable memory slots for working tools, which can be used for quickly and easily setting the oil pressure and oil flow at the push of a button when changing tools
- Rear and side area monitoring provide optimum visibility of the working area at all times

Comfortable Operation

Sliding two-piece Windscreen

The windscreen can be partially or fully slid into the roof to give an unrestricted view of the work area.

Radio with Hands-free Device

The radio can be equipped with an MP3-compatible USB slot and integrated hands-free device, which means that calls can even be taken while working with the machine. Operation of the radio is by means of the touchscreen colour display. Station search, volume control and mute can be controlled with ease. Simple operation for greater comfort.

Control Unit

The large touchscreen provides the operator with a fast, uncomplicated interface which delivers all the information required for working with the machine. A flat, intuitive menu system ensures that it can be readily understood so that the control unit can be used in a highly productive way.

Maintainability



Service Every Step of the Way – Simple, Fast and Reliable

Liebherr compact wheeled excavators are not only powerful, robust, precise and efficient, they also impress with the service-orientated machine design. Maintenance is performed quickly, simply and safely. This reduces maintenance costs and keeps machine downtimes to a minimum.

Simplified Maintenance Concept

Service-based Machine Design

The service-based machine design guarantees short servicing times, thus minimising maintenance costs due to the time it saves. All the maintenance points are easily accessible from the ground and easy to reach due to the large, wide-opening service doors. The enhanced service concept places the maintenance points close to each other and reduces their number to a minimum. This means that service work can be completed even more quickly and efficiently.

Hydraulic Oils with Added Value

Liebherr hydraulic oils achieve a service life of 6,000 operating hours plus. Instead of having defined change intervals, the results of the oil analysis (every 1,000 operating hours or after one year) determine when the oil needs to be changed. The unique Liebherr Hydraulic Plus oil can even achieve a service life of 8,000 operating hours plus at the same time reducing fuel consumption by up to 5%.

Your Competent Service Partner

Maintenance without Draining the Oil

A cut-off valve isolating the oil reservoir from the hydraulic system is fitted as standard. This allows simple maintenance work to be performed on the hydraulic components without having to drain off the hydraulic fluid. Reduced maintenance time for greater machine availability.

Remanufacturing

The Liebherr remanufacturing program offers cost-effective reconditioning of components to the highest quality standards. Various reconditioning levels available including replacement components and general overhaul or repair. The customer receives components with original part quality at a reduced cost.

Competent Advice and Service

Competent advice is given at Liebherr. Experienced specialists provide advice for your specific requirements: application-oriented sales support, service agreements, cost effective repair alternatives, original parts management, as well as remote data transmission for machine planning and fleet management.



Lubricating During Work

- Fully automatic central lubrication system for the attachment and swing ring
- Can be optionally expanded to the connecting link and quick coupler
- Lubricating without interrupting work for higher productivity

Excellent Service Access

- Large, wide-opening service doors
- Engine oil, fuel, air and cab air filters are easily and safely accessible from the ground
- The oil level in the hydraulic tank can be checked from the cab
- Short service times for more productivity

Rapid Spare Parts Service

- 24-hour delivery: Spare parts service is available for our dealers around the clock
- Electronic spare parts catalogue: Fast and reliable selection and ordering via the Liebherr online portal
- With online tracking, the current processing status of your order can be viewed at any time

Wheeled Excavator A 918 Compact Litronic

Overview

Superbly Designed Attachment for Maximum Reliability

- Various boom versions and stick lengths
- Liebherr hydraulic cylinders
- Pipe fracture safety valves hoisting and stick cylinders
- Overload warning device
- Driving oscillation damper (optional)
- Liebherr quick coupling systems (optional)
- Wide selection of Liebherr working tools (optional)

Elaborate Maintenance Concept for Maximum Productivity

- Fully automatic central lubrication system for uppercarriage and attachment
- Large, wide-opening service doors
- Central maintenance points accessible from the ground
- Hydraulic shut-off cock
- Cab air filter can be replaced quickly and conveniently from outside





Ergonomic Operator's Work Station for Maximum Comfort

- Operator's seat Comfort or Premium (optional)
- Automatic air-conditioning system
- 7" high resolution colour display with touchscreen operation
- Resonant arm console and ergonomic joysticks
- Folding arm console, left
- Proportional control with 4-way mini-joystick
- Joystick steering (optional)
- Large windows
- Protective grille at top and bottom, adjustable (optional)
- Convenient radio operation with hands-free device
- Tool Control for working tools
- LED headlights (optional)
- Rear and side monitor
- Skyview 360° – Camerasystem

Superior Technology for Highest Economy

- Liebherr diesel engine compliant with stage V
- Emissions treatment with Liebherr-SCRT technology
- Liebherr-Power-Efficiency (LPE)
- Load-sensing-control
- MODE selection (Sensitive, ECO, Power, Power-Plus)
- Sensor-controlled automatic idling system

Perfect Combination for Highest Possible Performance

- Short tail swing radius
- Various support versions, welded on
- Travel drive integrated in undercarriage
- Automatic working brake
- Liebherr tyres without intermediate ring

Technical Data



Diesel Engine

Rating per ISO 9249	115 kW (156 HP) at 1,800 RPM
Model	Liebherr D924
Type	4 cylinder in-line
Bore/Stroke	104/ 132 mm
Displacement	4.5 l
Engine operation	4-stroke diesel Common-Rail turbo-charged and after-cooled reduced emissions
Air cleaner	dry-type air cleaner with pre-cleaner, primary and safety elements
Engine idling	sensor controlled
Electrical system	
Voltage	24 V
Batteries	2 x 135 Ah/ 12 V
Alternator	three-phase current 28 V/ 140 A
Stage V	
Harmful emissions values	according to regulation (EU) 2016/1628
Emission control	Liebherr-SCRT technology
Fuel tank	250 l
Urea tank	46 l



Cooling System

Diesel engine	water-cooled compact cooling system consisting cooling unit for water, hydraulic oil and charge air with stepless thermostatically controlled fan, fans for radiator cleaning can be completely folded away
----------------------	--



Hydraulic Controls

Power distribution	via control valves with integrated safety valves, simultaneous and independent actuation of chassis, swing drive and equipment
Servo circuit	
Equipment and swing	with hydraulic pilot control and proportional joystick levers
Chassis	electroproportional via foot pedal
Additional functions	via switch or electroproportional foot pedals
Proportional control	proportionally acting transmitters on the joysticks for additional hydraulic functions



Hydraulic System

Hydraulic pump	Liebherr axial piston variable displacement pump
for equipment and travel drive	
Max. flow	300 l/min.
Max. pressure	350 bar
Hydraulic pump regulation and control	Liebherr-Synchron-Comfort-system (LSC) with electronic engine speed sensing regulation, pressure and flow compensation, torque controlled swing drive priority
Hydraulic tank	130 l
Hydraulic system	max. 300 l
Hydraulic oil filter	1 main return filter with integrated partial micro filtration (5 µm)
MODE selection	adjustment of engine and hydraulic performance via a mode pre-selector to match application, e.g. for especially economical and environmentally friendly operation or for maximum digging performance and heavy-duty jobs
S (Sensitive)	mode for precision work and lifting through very sensitive movements
E (Eco)	mode for especially economical and environmentally friendly operation
P (Power)	mode for high performance with low fuel consumption
P+ (Power-Plus)	mode for highest performance and for very heavy duty applications, suitable for continuous operation
Engine speed and performance setting	stepless alignment of engine output and hydraulic power via engine speed
Option	Tool Control: 20 preadjustable pump flows and pressures for add-on attachments



Swing Drive

Drive	Liebherr axial piston motor with integrated brake valve and torque control, Liebherr planetary reduction gear
Swing ring	Liebherr, sealed race ball bearing swing ring, internal teeth
Swing speed	0 – 10,0 RPM stepless
Swing torque	54 kNm
Holding brake	wet multi-disc (spring applied, pressure released)
Option	pedal controlled positioning swing brake slewing gear brake Comfort



Operator's Cab

Cab	ROPS safety cab structure (roll-over protection system) with individual windscreens or featuring a slide-in subpart under the ceiling, work headlights integrated in the ceiling, a door with a sliding window (can be opened on both sides), large stowing and depositing possibilities, shock-absorbing suspension, sounddamping insulating, tinted laminated safety glass, separate window shades for the sunroof window and windscreen
Operator's seat Standard	air cushioned operator's seat with 3D-adjustable armrests, headrest, lap belt, seat heater, manual weight adjustment, adjustable seat cushion inclination and length and mechanical lumbar vertebrae support
Operator's seat Comfort (Option)	in addition to operator's seat standard: lockable horizontal suspension, automatic weight adjustment, adjustable suspension stiffness, pneumatic lumbar vertebrae support and passive seat climatisation with active coal
Operator's seat Premium (Option)	in addition to operator's seat comfort: active electronic weight adjustment (automatic re-adjustment), pneumatic low frequency suspension and active seat climatisation with active coal and ventilator
Control system	joysticks with control consoles and swivel seat, folding left control console
Operation and displays	large high-resolution operating unit, self-explanatory, colour display with touchscreen, video-compatible, numerous setting, control and monitoring options, e.g. air conditioning control, fuel consumption, machine and attachment parameters
Air-conditioning	automatic air-conditioning, recirculated air function, fast de-icing and demisting at the press of a button, air vents can be operated via a menu; recirculated air and fresh air filters can be easily replaced and are accessible from the outside; heating-cooling unit, designed for extreme outside temperatures, sensors for solar radiation, inside and outside temperatures (country-dependent)
Refrigerant	R134a
Global warming potential	1,430
Quantity at 25 °C	1,300 g
CO ₂ equivalent	1.859 t
Vibration emission*	
Hand/arm vibrations	< 2.5 m/s ²
Whole-body vibrations	< 0.5 m/s ²
Measuring inaccuracy	according with standard EN 12096:1997



Undercarriage

Drive	oversized two speed power shift transmission with additional creeper speed, Liebherr axial piston motor with functional brake valve on both sides
Pulling force	127 kN
Travel speed	0 – 3.5 km/h stepless (creeper speed off-road) 0 – 7.0 km/h stepless (off-road) 0 – 13.0 km/h stepless (creeper speed on-road) 0 – 20.0 km/h stepless (road travel) 0 – max. 25.0 or 30.0 km/h Speeder (Option)
Driving operation	automotive driving using accelerator pedal, cruise control function: storage of variable accelerator pedal positions, both off-road and on-road
Axles	manual or automatic hydraulically controlled front axle oscillation lock
Service brake	two circuit travel brake system with accumulator; wet and backlash-free disc brake
Automatic digging brake	works automatically when driving off (accelerator pedal actuation) and when the machine is stationary (engagement); the digging brake engages automatically – can be coupled with automatic swing axle lock
Holding brake	wet multi-disc (spring applied, pressure released)
Stabilization	rear stabilizer blade (adjustable during travel for dozing) rear + front stabilizer blade rear outriggers + front stabilizer blade
Option	EW-undercarriage 2.75 m/9'



Equipment

Type	high-strength steel plates at highly stressed points for the toughest requirements. Complex and stable mountings of equipment and cylinders
Hydraulic cylinders	Liebherr cylinders with special seal system as well as shock absorption
Bearings	sealed, low maintenance



Complete Machine

Lubrication	Liebherr central lubrication system for upper-carriage and equipment, automatically
Noise emission	
ISO 6396	L _{pA} (inside cab) = 71 dB(A)
2000/14/EC	L _{WA} (surround noise) = 100 dB(A)

* for risk assessment according to 2002/44/EC see ISO/TR 25398:2006

Dimensions

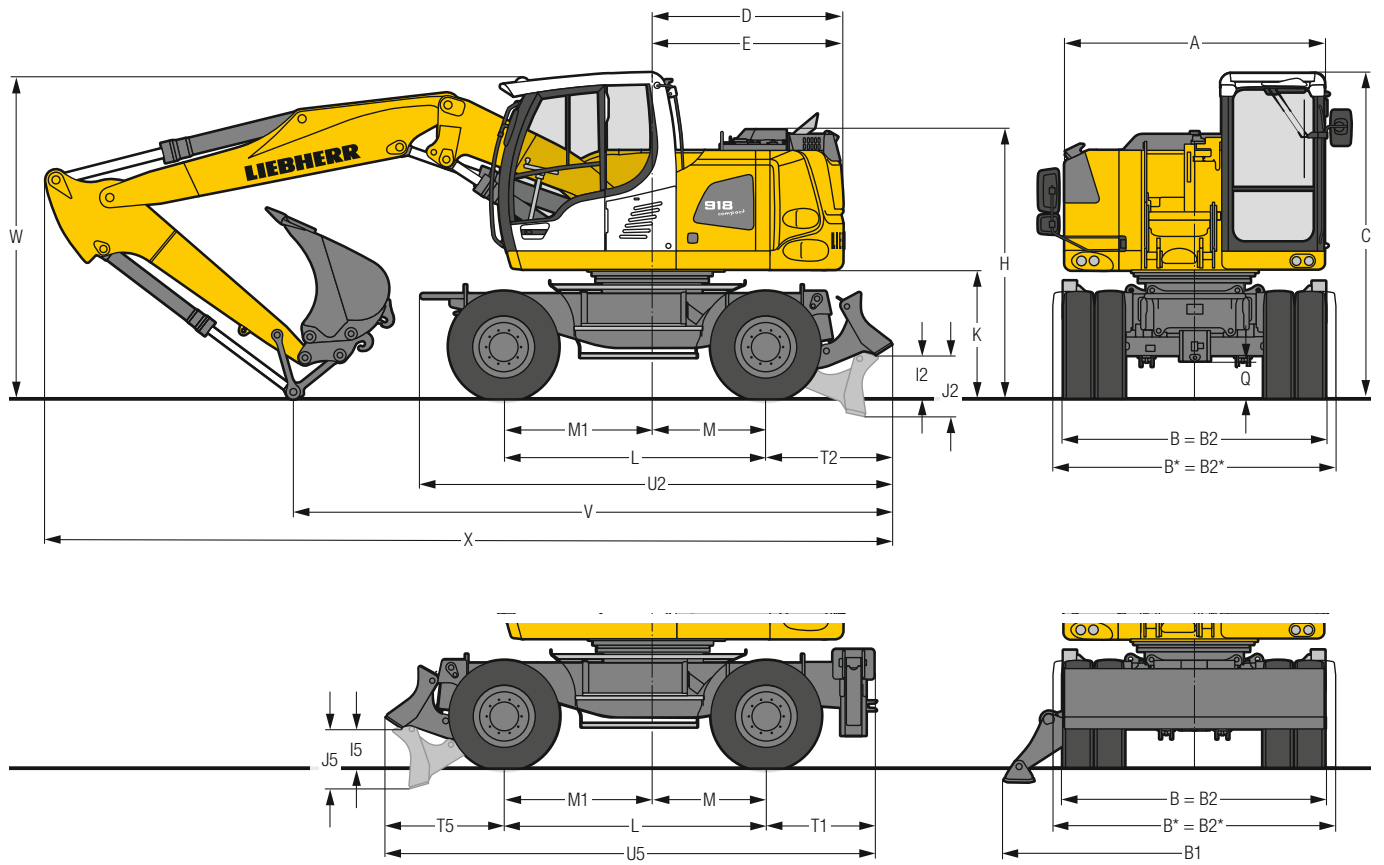

	mm
A	2,525
B	2,550
B*	2,750
B1	3,695
B2	2,550
B2*	2,750
C	3,165
D	1,850
E	1,850
H	2,590
I2	425
I5	380
J2	605
J5	585
K	1,230
L	2,540
M	1,100
M1	1,440
Q	350
T1	1,047
T2	1,230
T5	1,153
U2	4,575
U5	4,740

* EW-Undercarriage
E = Tail radius
Tyres 10.00-20

	Stick m	Two-piece boom 5.05 m		Mono boom 5.00 m	
		Rear blade mm	Rear outriggers + front blade mm	Rear blade mm	Rear outriggers + front blade mm
V	2.25	5,950	5,750	5,700	5,550
	2.45	5,850	5,650	5,450	5,700*
	2.65	5,450	5,750*	5,000*	5,350*
W	2.25	3,050	3,050	3,250	3,250
	2.45	3,100	3,100	3,250	3,250*
	2.65	3,100	3,100*	3,150*	3,150*
X	2.25	8,250	8,100	8,200	8,050
	2.45	8,250	8,100	8,200	8,450*
	2.65	8,250	8,500*	8,100*	8,450*

	Stick m	Offset two-piece boom 5.00 m		Offset mono boom 4.90 m	
		Rear blade mm	Rear outriggers + front blade mm	Rear blade mm	Rear outriggers + front blade mm
V	2.25	6,400	6,250	5,950	5,800
	2.45	5,850	5,700	5,450	5,750*
	2.65	–	–	5,300*	5,650*
W	2.25	3,250	3,250	3,300	3,300
	2.45	3,200	3,200	3,150	3,150*
	2.65	–	–	3,300*	3,300*
X	2.25	8,150	8,000	8,050	7,900
	2.45	8,200	8,050	8,100	8,350*
	2.65	–	–	8,000*	8,350*

Dimensions are with attachment over steering axle

* Attachment over digging axle for shorter transport dimensions

W = Max. ground clearance including approx. 150 mm piping

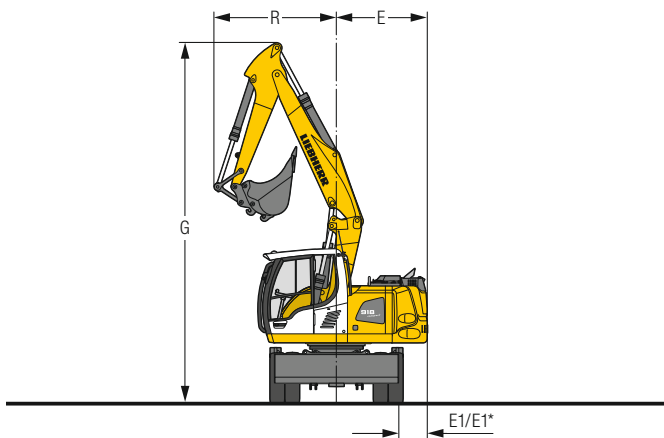

Boom	Stick m	G mm	R mm	E mm	E1/E1* mm
Two-piece boom	2.25	7,375	2,430	1,850	580/495*
Two-piece boom	2.45	7,375	2,505	1,850	580/495*
Two-piece boom	2.65	7,375	2,575	1,850	580/495*

* EW-Undercarriage

Backhoe Bucket

with Two-Piece Boom 5.05 m

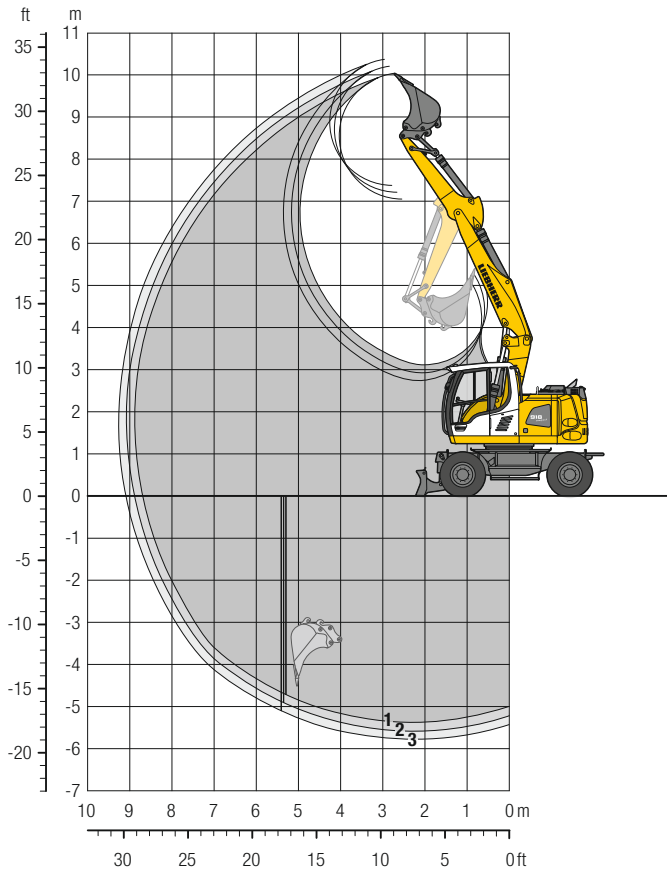

Digging Envelope

with quick coupler		1	2	3
Stick length	m	2.25	2.45	2.65
Max. digging depth	m	5.40	5.60	5.80
Max. reach at ground level	m	8.70	8.90	9.10
Max. dumping height	m	7.05	7.20	7.40
Max. teeth height	m	10.05	10.20	10.40
Min. equipment radius	m	2.43	2.51	2.58

Digging Forces

without quick coupler		1	2	3
Max. digging force (ISO 6015)	kN	81.0	76.0	71.6
	t	8.3	7.7	7.3
Max. breakout force (ISO 6015)	kN	98.4	98.4	98.4
	t	10.0	10.0	10.0

Max. breakout force with ripper bucket

125.7 kN (12.8 t)

Operating Weight

The operating weight includes the basic machine with 8 tyres plus intermediate rings, two-piece boom 5.05 m, stick 2.45 m, quick coupler SWA 33 and bucket 850 mm/0.60 m³.

Undercarriage versions	Weight (kg)
A 918 Compact Litronic with rear blade	17,700
A 918 Compact Litronic with rear outriggers + front blade	18,600
A 918 Compact EW Litronic with rear blade	17,800
A 918 Compact EW Litronic with rear outriggers + front blade	18,700

Buckets Machine stability per ISO 10567* (75% of tipping capacity)

Cutting width mm	Capacity ISO 7451 ¹⁾ m ³	Weight kg	Stabilizers raised			Rear blade down			Rear outriggers + front blade down			EW Stabilizers raised			EW Rear blade down			EW Rear outriggers + front blade down		
			Stick length (m)			Stick length (m)			Stick length (m)			Stick length (m)			Stick length (m)			Stick length (m)		
			2.25	2.45	2.65	2.25	2.45	2.65	2.25	2.45	2.65	2.25	2.45	2.65	2.25	2.45	2.65	2.25	2.45	2.65
500 ²⁾	0.30	290	■	■	■	■	■	■	■	■	■	■	■	■	■	■	■	■	■	■
650 ²⁾	0.42	350	■	■	■	■	■	■	■	■	■	■	■	■	■	■	■	■	■	■
850 ²⁾	0.60	400	■	■	■	■	■	■	■	■	■	■	■	■	■	■	■	■	■	■
1,050 ²⁾	0.80	480	■	■	■	■	■	■	■	■	■	■	■	■	■	■	■	■	■	■
1,250 ²⁾	0.95	530	△	△	△	■	■	■	■	■	■	■	■	■	■	■	■	■	■	■
500 ³⁾	0.30	310	■	■	■	■	■	■	■	■	■	■	■	■	■	■	■	■	■	■
650 ³⁾	0.42	360	■	■	■	■	■	■	■	■	■	■	■	■	■	■	■	■	■	■
850 ³⁾	0.60	420	■	■	■	■	■	■	■	■	■	■	■	■	■	■	■	■	■	■
1,050 ³⁾	0.80	500	■	■	■	■	■	■	■	■	■	■	■	■	■	■	■	■	■	■
1,250 ³⁾	0.95	550	△	△	△	■	■	■	■	■	△	■	■	△	■	■	■	■	■	■
500 ⁴⁾	0.32	280	■	■	■	■	■	■	■	■	■	■	■	■	■	■	■	■	■	■
650 ⁴⁾	0.45	330	■	■	■	■	■	■	■	■	■	■	■	■	■	■	■	■	■	■
850 ⁴⁾	0.65	380	■	■	■	■	■	■	■	■	■	■	■	■	■	■	■	■	■	■
1,050 ⁴⁾	0.85	460	■	■	■	■	■	■	■	■	■	■	■	■	■	■	■	■	■	■
1,250 ⁴⁾	1.05	500	△	△	-	■	△	△	■	■	■	■	△	△	■	■	■	■	■	■

* Indicated loads are based on ISO 10567 and do not exceed 75% of tipping or 87% of hydraulic capacity, max. stick length without quick coupler, lifted 360° on firm with blocked oscillating axle

¹⁾ comparable with SAE (heaped)

²⁾ Bucket with teeth ³⁾ Bucket with teeth in HD-version ⁴⁾ Bucket with cutting edge (also available in HD-version)

Buckets with 500 mm cutting width with limited digging depth

Max. material weight ■ = ≤ 1.8 t/m³, ■ = ≤ 1.5 t/m³, △ = ≤ 1.2 t/m³, - = not authorised

Lift Capacities

with Two-Piece Boom 5.05 m

Stick 2.25 m

m	Undercarriage stabilized		3.0 m		4.5 m		6.0 m		7.5 m		m		
	rear	front	Blade	Outriggers	Blade	Outriggers	Blade	Outriggers	Blade	Outriggers			
7.5	—	—	—	—	3.4*	3.4*	—	—	—	—	2.4*	2.4*	4.9
	Blade	—	—	—	3.4*	3.4*	—	—	—	—	2.4*	2.4*	
6.0	—	—	—	—	4.5	4.7*	2.7	3.1*	—	—	2.2*	2.2*	6.3
	Blade	—	—	—	4.7*	4.7*	3.0	3.1*	—	—	2.2*	2.2*	
4.5	—	—	6.2*	6.2*	4.4	5.6*	2.8	4.5	—	—	2.0	2.1*	7.1
	Blade	—	6.2*	6.2*	4.8	5.6*	3.1	4.8*	—	—	2.1*	2.1*	
3.0	—	—	7.5	10.1*	4.2	6.6*	2.7	4.4	—	—	1.7	2.1*	7.5
	Blade	—	8.3	10.1*	4.7	6.6*	3.0	5.1*	—	—	2.0	2.1*	
1.5	—	—	10.8*	10.8*	6.6*	6.6*	4.5	5.1*	—	—	2.1*	2.1*	7.6
	Blade	—	7.3	10.8*	4.2	6.5	2.6	4.3	1.7	2.9*	1.6	2.3*	
0	—	—	8.1	10.8*	4.6	7.3*	2.9	5.4*	1.9	2.9*	1.9	2.3*	7.4
	Blade	—	10.8*	10.8*	6.7	7.3*	4.5	5.4*	2.9*	2.9*	2.3*	2.3*	
-1.5	—	—	7.2	11.6*	4.0	6.6	2.5	4.2	—	—	1.7	2.6*	6.8
	Blade	—	8.2	11.6*	4.5	7.4*	2.8	5.4*	—	—	1.9	2.6*	
-3.0	—	—	11.6*	11.6*	6.7	7.4*	4.3	5.4*	—	—	2.6*	2.6*	5.8
	Blade	—	6.8	11.8*	3.7	6.5	2.3	4.0	—	—	1.8	3.2*	
-4.5	—	—	7.8	11.8*	4.2	7.6*	2.6	5.3*	—	—	2.1	3.2*	7.0
	Blade	—	11.8*	11.8*	6.7	7.6*	4.2	5.3*	—	—	3.2*	3.2*	

Stick 2.45 m

m	Undercarriage stabilized		3.0 m		4.5 m		6.0 m		7.5 m		m		
	rear	front	Blade	Outriggers	Blade	Outriggers	Blade	Outriggers	Blade	Outriggers			
7.5	—	—	—	—	3.6*	3.6*	—	—	—	—	2.2*	2.2*	5.2
	Blade	—	—	—	3.6*	3.6*	—	—	—	—	2.2*	2.2*	
6.0	—	—	—	—	4.4*	4.4*	2.7	3.3*	—	—	2.0*	2.0*	6.5
	Blade	—	—	—	4.4*	4.4*	3.0	3.3*	—	—	2.0*	2.0*	
4.5	—	—	5.3*	5.3*	4.4	5.4*	2.8	4.4	—	—	1.9	1.9*	7.3
	Blade	—	5.3*	5.3*	4.8	5.4*	3.1	4.6*	—	—	1.9*	1.9*	
3.0	—	—	7.5	9.7*	4.2	6.4*	2.8	4.4	1.7	2.8*	1.6	1.9*	7.7
	Blade	—	8.3	9.7*	4.6	6.4*	3.0	5.0*	2.0	2.8*	1.9	1.9*	
1.5	—	—	10.7*	10.7*	6.4*	6.4*	4.5	5.0*	2.8*	2.8*	1.9*	1.9*	7.8
	Blade	—	7.3	10.7*	4.2	6.5	2.7	4.4	1.7	2.9	1.6	2.1*	
0	—	—	8.1	10.7*	4.6	7.2*	2.9	5.3*	1.9	3.5*	1.8	2.1*	7.6
	Blade	—	10.7*	10.7*	6.6	7.2*	4.5	5.3*	3.0	3.5*	2.1*	2.1*	
-1.5	—	—	7.3	11.4*	4.0	6.5	2.5	4.2	1.6	2.9	1.6	2.3*	7.0
	Blade	—	8.1	11.4*	4.5	7.4*	2.8	5.4*	1.8	2.9*	1.8	2.3*	
-3.0	—	—	11.4*	11.4*	6.7	7.4*	4.3	5.4*	2.9*	2.9*	2.3*	2.3*	6.1
	Blade	—	6.8	11.7*	3.8	6.5	2.3	4.0	—	—	1.7	2.8*	
-4.5	—	—	7.8	11.7*	4.2	7.5*	2.6	5.4*	—	—	2.0	2.8*	7.0
	Blade	—	11.7*	11.7*	6.7	7.5*	4.2	5.4*	—	—	2.8*	2.8*	

Stick 2.65 m

m	Undercarriage stabilized		3.0 m		4.5 m		6.0 m		7.5 m		m		
	rear	front	Blade	Outriggers	Blade	Outriggers	Blade	Outriggers	Blade	Outriggers			
7.5	—	—	—	—	3.6*	3.6*	—	—	—	—	2.0*	2.0*	5.5
	Blade	—	—	—	3.6*	3.6*	—	—	—	—	2.0*	2.0*	
6.0	—	—	—	—	4.0*	4.0*	2.8	3.3*	—	—	1.8*	1.8*	6.7
	Blade	—	—	—	4.0*	4.0*	3.1	3.3*	—	—	1.8*	1.8*	
4.5	—	—	—	—	4.4	4.8*	2.8	4.3*	—	—	1.7*	1.7*	7.5
	Blade	—	—	—	4.8	4.8*	3.1	4.3*	—	—	1.7*	1.7*	
3.0	—	—	7.5	9.2*	4.2	6.2*	2.8	4.4	1.8	3.0	1.6	1.7*	7.9
	Blade	—	8.3	9.2*	4.6	6.2*	3.1	4.9*	2.0	3.2*	1.7*	1.7*	
1.5	—	—	9.2*	9.2*	6.2*	6.2*	4.5	4.9*	3.1	3.2*	1.7*	1.7*	8.0
	Blade	—	7.3	10.6*	4.1	6.5	2.7	4.3	1.7	2.9	1.5	1.9*	
0	—	—	8.1	10.6*	4.5	7.1*	3.0	5.2*	1.9	3.9*	1.7	1.9*	7.8
	Blade	—	10.6*	10.6*	6.6	7.1*	4.4	5.2*	3.0	3.9*	1.9*	1.9*	
-1.5	—	—	7.3	11.3*	4.0	6.5	2.5	4.2	1.6	2.8	1.5	2.1*	7.3
	Blade	—	8.1	11.3*	4.5	7.3*	2.8	5.3*	1.8	3.7*	1.7	2.1*	
-3.0	—	—	11.3*	11.3*	6.6	7.3*	4.3	5.3*	2.9	3.7*	2.1*	2.1*	6.3
	Blade	—	6.8	11.7*	3.8	6.6	2.3	4.0	—	—	1.6	2.5*	
-4.5	—	—	7.8	11.7*	4.2	7.4*	2.6	5.4*	—	—	1.9	2.5*	3.4
	Blade	—	11.7*	11.7*	6.8	7.4*	4.2	5.4*	—	—	2.5*	2.5*	

 **Height**  **Can be slewed through 360°**  **In longitudinal position of undercarriage**  **Max. reach** * **Limited by hydr. capacity**

The lift capacities on the load lift hook of the Liebherr quick coupler SWA 33 without attachment are stated in metric tons (t) and are valid on a firm, level supporting surface with blocked oscillating axle. These capacities can be slewed through 360° with the undercarriage in the transverse position. Capacities in the longitudinal position of the undercarriage (+/- 15°) are specified over the steering axle with the stabilizers raised and over the rigid axle with the stabilizers down. The values apply when the adjusting cylinder is in the optimal position. Indicated loads based on the ISO 10567 standard and do not exceed 75% of tipping or 87% of hydraulic capacity, or are limited by the permissible load of the load lift hook on the quick coupler (max. 5 t). Without the quick coupler, lift capacities will increase by up to 110 kg.

In accordance with the harmonized European Standard EN 474-5, hydraulic excavators used for lifting operations must be equipped with pipe fracture safety valves, an overload warning device, a load lift hook and a lift capacity chart.

Lift Capacities

with Two-Piece Boom 5.05 m, EW-Undercarriage

Stick 2.25 m

m	Undercarriage stabilized		3.0 m		4.5 m		6.0 m		7.5 m		m		
	rear	front	rear	front	rear	front	rear	front	rear	front			
7.5	Blade	—	—	—	3.4*	3.4*	—	—	—	—	2.4*	2.4*	4.9
	Outriggers	Blade	—	—	3.4*	3.4*	—	—	—	—	2.4*	2.4*	
6.0	Blade	—	—	—	4.7*	4.7*	3.0	3.1*	—	—	2.2*	2.2*	6.3
	Outriggers	Blade	—	—	4.7*	4.7*	3.1*	3.1*	—	—	2.2*	2.2*	
4.5	Blade	—	6.2*	6.2*	4.8	5.6*	3.0	4.5	—	—	2.1*	2.1*	7.1
	Outriggers	Blade	6.2*	6.2*	5.2	5.6*	3.4	4.8*	—	—	2.1*	2.1*	
3.0	Blade	—	8.3	10.1*	4.6	6.6*	3.0	4.4	—	—	1.9	2.1*	7.5
	Outriggers	Blade	10.1*	10.1*	6.6*	6.6*	4.7	5.1*	—	—	2.1*	2.1*	
1.5	Blade	—	8.1	10.8*	4.6	6.6	2.9	4.4	1.9	2.9*	1.8	2.3*	7.6
	Outriggers	Blade	10.8*	10.8*	6.9	7.3*	4.7	5.4*	2.9*	2.9*	2.3*	2.3*	
0	Blade	—	8.2	11.6*	4.4	6.6	2.7	4.2	—	—	1.9	2.6*	7.4
	Outriggers	Blade	11.6*	11.6*	7.0	7.4*	4.5	5.4*	—	—	2.1	2.6*	
-1.5	Blade	—	7.7	11.8*	4.2	6.6	2.6	4.0	—	—	2.1	3.2*	6.8
	Outriggers	Blade	11.8*	11.8*	7.1	7.6*	4.4	5.3*	—	—	2.3	3.2*	
-3.0	Blade	—	7.5	11.9*	3.9	6.3	—	—	—	—	2.6	3.3*	5.8
	Outriggers	Blade	11.9*	11.9*	6.8	6.8*	—	—	—	—	2.9	3.3*	
-4.5	Blade	—	—	—	—	—	—	—	—	—	—	—	—
	Outriggers	Blade	—	—	—	—	—	—	—	—	—	—	

Stick 2.45 m

m	Undercarriage stabilized		3.0 m		4.5 m		6.0 m		7.5 m		m		
	rear	front	rear	front	rear	front	rear	front	rear	front			
7.5	Blade	—	—	—	3.6*	3.6*	—	—	—	—	2.2*	2.2*	5.2
	Outriggers	Blade	—	—	3.6*	3.6*	—	—	—	—	2.2*	2.2*	
6.0	Blade	—	—	—	4.4*	4.4*	3.0	3.3*	—	—	2.0*	2.0*	6.5
	Outriggers	Blade	—	—	4.4*	4.4*	3.3*	3.3*	—	—	2.0*	2.0*	
4.5	Blade	—	5.3*	5.3*	4.8	5.4*	3.1	4.5	—	—	1.9*	1.9*	7.3
	Outriggers	Blade	5.3*	5.3*	5.2	5.4*	3.4	4.6*	—	—	1.9*	1.9*	
3.0	Blade	—	8.3	9.7*	4.6	6.4*	3.0	4.4	1.9	2.8*	1.8	1.9*	7.7
	Outriggers	Blade	9.7*	9.7*	6.4*	6.4*	4.7	5.0*	2.2	2.8*	1.9*	1.9*	
1.5	Blade	—	8.1	10.7*	4.5	6.5	2.9	4.4	1.9	2.9	1.8	2.1*	7.8
	Outriggers	Blade	10.7*	10.7*	6.9	7.2*	4.6	5.3*	2.1	3.5*	2.0	2.1*	
0	Blade	—	8.1	11.4*	4.4	6.5	2.8	4.2	1.8	2.9*	1.8	2.3*	7.6
	Outriggers	Blade	11.4*	11.4*	6.9	7.4*	4.5	5.4*	2.1	2.9*	2.0	2.3*	
-1.5	Blade	—	7.7	11.8*	4.2	6.6	2.6	4.0	—	—	2.0	2.8*	7.0
	Outriggers	Blade	11.8*	11.8*	7.1	7.5*	4.4	5.4*	—	—	2.2	2.8*	
-3.0	Blade	—	7.5	12.1*	3.9	6.3	2.5	3.6*	—	—	2.4	3.3*	6.1
	Outriggers	Blade	12.1*	12.1*	6.8	7.1*	3.6*	3.6*	—	—	3.3*	3.3*	
-4.5	Blade	—	—	—	—	—	—	—	—	—	—	—	—
	Outriggers	Blade	—	—	—	—	—	—	—	—	—	—	

Stick 2.65 m

m	Undercarriage stabilized		3.0 m		4.5 m		6.0 m		7.5 m		m		
	rear	front	rear	front	rear	front	rear	front	rear	front			
7.5	Blade	—	—	—	3.6*	3.6*	—	—	—	—	2.0*	2.0*	5.5
	Outriggers	Blade	—	—	3.6*	3.6*	—	—	—	—	2.0*	2.0*	
6.0	Blade	—	—	—	4.0*	4.0*	3.0	3.3*	—	—	1.8*	1.8*	6.7
	Outriggers	Blade	—	—	4.0*	4.0*	3.3*	3.3*	—	—	1.8*	1.8*	
4.5	Blade	—	—	—	4.8	4.8*	3.1	4.3*	—	—	1.7*	1.7*	7.5
	Outriggers	Blade	—	—	4.8*	4.8*	3.4	4.3*	—	—	1.7*	1.7*	
3.0	Blade	—	8.3	9.3*	4.6	6.2*	3.1	4.4	2.0	3.0	1.8*	1.8*	7.9
	Outriggers	Blade	9.3*	9.3*	6.2*	6.2*	4.7	4.9*	3.2*	3.2*	1.8*	1.8*	
1.5	Blade	—	8.0	10.6*	4.5	6.5	3.0	4.4	1.9	3.0	1.7	1.9*	8.0
	Outriggers	Blade	10.6*	10.6*	6.9	7.1*	4.6	5.2*	3.2	3.9*	1.9*	1.9*	
0	Blade	—	8.0	11.3*	4.5	6.5	2.8	4.2	1.8	2.9	1.7	2.1*	7.8
	Outriggers	Blade	11.3*	11.3*	6.9	7.3*	4.5	5.3*	3.1	3.7*	1.9	2.1*	
-1.5	Blade	—	7.7	11.7*	4.2	6.6	2.6	4.1	—	—	1.8	2.5*	7.3
	Outriggers	Blade	11.7*	11.7*	7.1	7.4*	4.4	5.4*	—	—	2.1	2.5*	
-3.0	Blade	—	7.6	12.1*	3.9	6.3	2.5	3.9	—	—	2.3	3.3*	6.3
	Outriggers	Blade	12.1*	12.1*	6.8	7.4*	4.1*	4.1*	—	—	3.3*	3.3*	
-4.5	Blade	—	7.3	7.7*	—	—	—	—	—	—	5.9	6.2*	3.4
	Outriggers	Blade	7.7*	7.7*	—	—	—	—	—	—	6.2*	6.2*	

Height Can be slewed through 360° In longitudinal position of undercarriage Max. reach * Limited by hydr. capacity

The lift capacities on the load lift hook of the Liebherr quick coupler SWA 33 without attachment are stated in metric tons (t) and are valid on a firm, level supporting surface with blocked oscillating axle. These capacities can be slewed through 360° with the undercarriage in the transverse position. Capacities in the longitudinal position of the undercarriage (+/- 15°) are specified over the steering axle with the stabilizers raised and over the rigid axle with the stabilizers down. The values apply when the adjusting cylinder is in the optimal position. Indicated loads based on the ISO 10567 standard and do not exceed 75% of tipping or 87% of hydraulic capacity, or are limited by the permissible load of the load lift hook on the quick coupler (max. 5 t). Without the quick coupler, lift capacities will increase by up to 110 kg.

In accordance with the harmonized European Standard EN 474-5, hydraulic excavators used for lifting operations must be equipped with pipe fracture safety valves, an overload warning device, a load lift hook and a lift capacity chart.

Backhoe Bucket

with Mono Boom 5.00 m

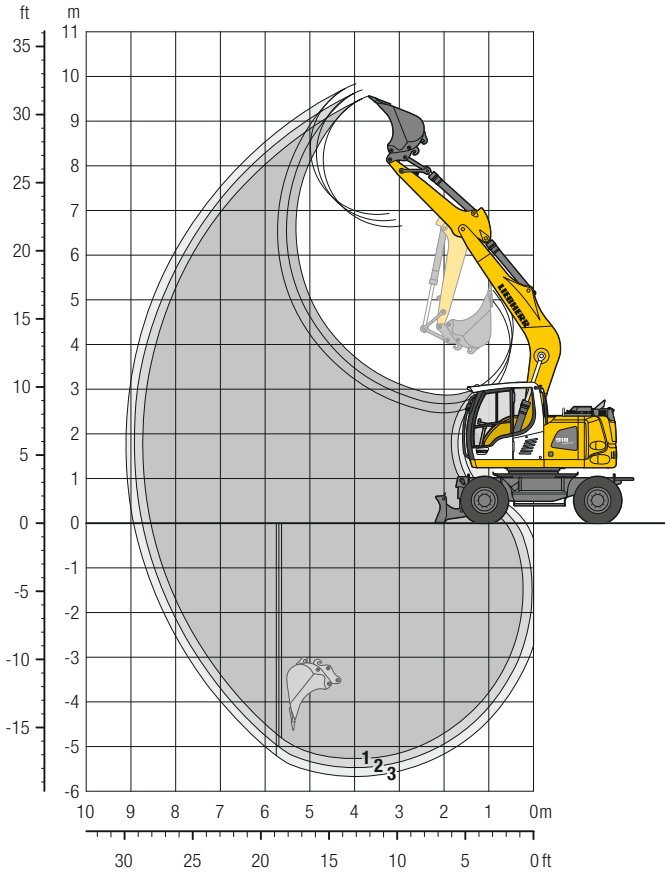

Digging Envelope

with quick coupler		1	2	3
Stick length	m	2.25	2.45	2.65
Max. digging depth	m	5.30	5.50	5.70
Max. reach at ground level	m	8.55	8.75	8.95
Max. dumping height	m	6.65	6.80	6.95
Max. teeth height	m	9.55	9.70	9.85
Min. equipment radius	m	2.37	2.40	2.44

Digging Forces

without quick coupler		1	2	3
Max. digging force (ISO 6015)	kN	81.0	76.0	71.6
	t	8.3	7.7	7.3
Max. breakout force (ISO 6015)	kN	98.4	98.4	98.4
	t	10.0	10.0	10.0

Max. breakout force with ripper bucket 125.7 kN (12.8 t)

Operating Weight

The operating weight includes the basic machine with 8 tyres plus intermediate rings, mono boom 5.00 m, stick 2.45 m, quick coupler SWA 33 and bucket 850 mm / 0.60 m³.

Undercarriage versions	Weight (kg)
A 918 Compact Litronic with rear blade	17,400
A 918 Compact Litronic with rear outriggers + front blade	18,300
A 918 Compact EW Litronic with rear blade	17,500
A 918 Compact EW Litronic with rear outriggers + front blade	18,400

Buckets Machine stability per ISO 10567* (75% of tipping capacity)

Cutting width mm	Capacity ISO 7451 ¹⁾ m ³	Weight kg	Stabilizers raised			Rear blade down			Rear outriggers + front blade down			EW Stabilizers raised			EW Rear blade down			EW Rear outriggers + front blade down		
			Stick length (m)			Stick length (m)			Stick length (m)			Stick length (m)			Stick length (m)			Stick length (m)		
			2.25	2.45	2.65	2.25	2.45	2.65	2.25	2.45	2.65	2.25	2.45	2.65	2.25	2.45	2.65	2.25	2.45	2.65
500 ²⁾	0.30	290	■	■	■	■	■	■	■	■	■	■	■	■	■	■	■	■	■	■
650 ²⁾	0.42	350	■	■	■	■	■	■	■	■	■	■	■	■	■	■	■	■	■	■
850 ²⁾	0.60	400	■	■	■	■	■	■	■	■	■	■	■	■	■	■	■	■	■	■
1,050 ²⁾	0.80	480	■	■	■	■	■	■	■	■	■	■	■	■	■	■	■	■	■	■
1,250 ²⁾	0.95	530	■	△	△	■	■	■	■	■	■	■	■	■	■	■	■	■	■	■
500 ³⁾	0.30	310	■	■	■	■	■	■	■	■	■	■	■	■	■	■	■	■	■	■
650 ³⁾	0.42	360	■	■	■	■	■	■	■	■	■	■	■	■	■	■	■	■	■	■
850 ³⁾	0.60	420	■	■	■	■	■	■	■	■	■	■	■	■	■	■	■	■	■	■
1,050 ³⁾	0.80	500	■	■	■	■	■	■	■	■	■	■	■	■	■	■	■	■	■	■
1,250 ³⁾	0.95	550	■	△	△	■	■	■	■	■	■	■	■	■	■	■	■	■	■	■
500 ⁴⁾	0.32	280	■	■	■	■	■	■	■	■	■	■	■	■	■	■	■	■	■	■
650 ⁴⁾	0.45	330	■	■	■	■	■	■	■	■	■	■	■	■	■	■	■	■	■	■
850 ⁴⁾	0.65	380	■	■	■	■	■	■	■	■	■	■	■	■	■	■	■	■	■	■
1,050 ⁴⁾	0.85	460	■	■	■	■	■	■	■	■	■	■	■	■	■	■	■	■	■	■
1,250 ⁴⁾	1.05	500	△	△	△	■	■	△	■	■	■	■	△	△	■	■	■	■	■	■

* Indicated loads are based on ISO 10567 and do not exceed 75% of tipping or 87% of hydraulic capacity, max. stick length without quick coupler, lifted 360° on firm with blocked oscillating axle

¹⁾ comparable with SAE (heaped)

²⁾ Bucket with teeth ³⁾ Bucket with teeth in HD-version ⁴⁾ Bucket with cutting edge (also available in HD-version)

Buckets with 500 mm cutting width with limited digging depth

Max. material weight ■ = ≤ 1.8 t/m³, ■ = ≤ 1.5 t/m³, △ = ≤ 1.2 t/m³, - = not authorised

Lift Capacities

with Mono Boom 5.00 m

Stick 2.25 m

m	Undercarriage stabilized		3.0 m		4.5 m		6.0 m		7.5 m		m	
	rear	front	Blade	Outriggers	Blade	Outriggers	Blade	Outriggers	Blade	Outriggers		
7.5	—	—	—	—	2.6*	2.6*	—	—	—	—	2.4*	2.4*
	Blade	—	—	—	2.6*	2.6*	—	—	—	—	2.4*	2.4*
6.0	—	—	—	—	4.0*	4.0*	2.3*	2.3*	—	—	2.1*	2.1*
	Blade	—	—	—	4.0*	4.0*	2.3*	2.3*	—	—	2.1*	2.1*
4.5	—	—	—	—	4.2	4.6*	2.6	4.1*	—	—	2.1	2.1*
	Blade	—	—	—	4.6*	4.6*	2.9	4.1*	—	—	2.1*	2.1*
3.0	—	—	6.9	8.7*	3.8	5.7*	2.5	4.2	—	—	1.8	2.2*
	Blade	—	7.9	8.7*	4.3	5.7*	2.8	4.6*	—	—	2.0	2.2*
1.5	—	—	6.0	6.1*	3.5	6.2	2.3	4.1	—	—	1.7	2.4*
	Blade	—	6.1*	6.1*	3.9	6.8*	2.6	5.1*	—	—	1.9	2.4*
0	—	—	5.8	7.0*	3.3	6.0	2.2	3.9	—	—	1.7	2.8*
	Blade	—	6.7	7.0*	3.7	7.3*	2.5	5.4*	—	—	1.9	2.8*
-1.5	—	—	5.8	10.1*	3.2	5.9	2.2	3.9	—	—	1.9	3.4
	Blade	—	6.7	10.1*	3.6	7.2*	2.5	5.2*	—	—	2.2	3.6*
-3.0	—	—	5.9	8.9*	3.2	5.9	—	—	—	—	2.4	4.3
	Blade	—	6.8	8.9*	3.7	6.2*	—	—	—	—	2.7	4.7*
-4.5	—	—	—	—	—	—	—	—	—	—	—	—
	Blade	—	—	—	—	—	—	—	—	—	—	—

Stick 2.45 m

m	Undercarriage stabilized		3.0 m		4.5 m		6.0 m		7.5 m		m	
	rear	front	Blade	Outriggers	Blade	Outriggers	Blade	Outriggers	Blade	Outriggers		
7.5	—	—	—	—	3.0*	3.0*	—	—	—	—	2.2*	2.2*
	Blade	—	—	—	3.0*	3.0*	—	—	—	—	2.2*	2.2*
6.0	—	—	—	—	3.7*	3.7*	2.7	2.7*	—	—	1.9*	1.9*
	Blade	—	—	—	3.7*	3.7*	2.7*	2.7*	—	—	1.9*	1.9*
4.5	—	—	—	—	4.2	4.3*	2.6	4.0*	—	—	1.9*	1.9*
	Blade	—	—	—	4.3*	4.3*	2.9	4.0*	—	—	1.9*	1.9*
3.0	—	—	7.1	8.1*	3.9	5.5*	2.5	4.2	1.7	2.0*	1.7	2.0*
	Blade	—	8.0	8.1*	4.3	5.5*	2.8	4.5*	1.9	2.0*	1.9	2.0*
1.5	—	—	6.1	7.0*	3.5	6.2	2.3	4.0	1.7	2.7*	1.6	2.1*
	Blade	—	7.0	7.0*	3.9	6.6*	2.6	5.0*	1.9	2.7*	1.8	2.1*
0	—	—	5.7	7.1*	3.2	5.9	2.2	3.9	—	—	1.6	2.5*
	Blade	—	6.6	7.1*	3.7	7.3*	2.5	5.3*	—	—	1.9	2.5*
-1.5	—	—	5.7	9.7*	3.1	5.8	2.1	3.8	—	—	1.8	3.2*
	Blade	—	6.6	9.7*	3.6	7.2*	2.4	5.2*	—	—	2.0	3.2*
-3.0	—	—	5.8	9.2*	3.2	5.9	—	—	—	—	2.2	4.0
	Blade	—	6.7	9.2*	3.6	6.4*	—	—	—	—	2.5	4.6*
-4.5	—	—	—	—	—	—	—	—	—	—	—	—
	Blade	—	—	—	—	—	—	—	—	—	—	—

Stick 2.65 m

m	Undercarriage stabilized		3.0 m		4.5 m		6.0 m		7.5 m		m	
	rear	front	Blade	Outriggers	Blade	Outriggers	Blade	Outriggers	Blade	Outriggers		
7.5	—	—	—	—	3.1*	3.1*	—	—	—	—	2.0*	2.0*
	Blade	—	—	—	3.1*	3.1*	—	—	—	—	2.0*	2.0*
6.0	—	—	—	—	—	—	2.7	2.9*	—	—	1.8*	1.8*
	Blade	—	—	—	—	—	2.9*	2.9*	—	—	1.8*	1.8*
4.5	—	—	—	—	4.1*	4.1*	2.7	3.8*	—	—	1.7*	1.7*
	Blade	—	—	—	4.1*	4.1*	3.0	3.8*	—	—	1.7*	1.7*
3.0	—	—	7.2	7.6*	3.9	5.2*	2.5	4.2	1.7	2.5*	1.6	1.8*
	Blade	—	7.6*	7.6*	4.3	5.2*	2.8	4.3*	1.9	2.5*	1.8*	1.8*
1.5	—	—	6.1	8.0*	3.5	6.2	2.3	4.0	1.6	2.9	1.5	1.9*
	Blade	—	7.0	8.0*	3.9	6.5*	2.6	4.9*	1.9	3.2*	1.7	1.9*
0	—	—	5.7	7.2*	3.2	5.9	2.2	3.9	1.6	2.7*	1.5	2.2*
	Blade	—	6.6	7.2*	3.7	7.2*	2.5	5.2*	1.8	2.7*	1.8	2.2*
-1.5	—	—	5.6	9.4*	3.1	5.8	2.1	3.8	—	—	1.7	2.8*
	Blade	—	6.5	9.4*	3.6	7.2*	2.4	5.2*	—	—	1.9	2.8*
-3.0	—	—	5.7	9.4*	3.1	5.8	2.1	3.8	—	—	2.1	3.7
	Blade	—	6.7	9.4*	3.6	6.5*	2.4	4.6*	—	—	2.4	4.1*
-4.5	—	—	—	—	—	—	—	—	—	—	3.4	4.5*
	Blade	—	—	—	—	—	—	—	—	—	3.8	4.5*

Height Can be slewed through 360° In longitudinal position of undercarriage Max. reach * Limited by hydr. capacity

The lift capacities on the load lift hook of the Liebherr quick coupler SWA 33 without attachment are stated in metric tons (t) and are valid on a firm, level supporting surface with blocked oscillating axle. These capacities can be slewed through 360° with the undercarriage in the transverse position. Capacities in the longitudinal position of the undercarriage (+/- 15°) are specified over the steering axle with the stabilizers raised and over the rigid axle with the stabilizers down. Indicated loads based on the ISO 10567 standard and do not exceed 75% of tipping or 87% of hydraulic capacity, or are limited by the permissible load of the load lift hook on the quick coupler (max. 5 t). Without the quick coupler, lift capacities will increase by up to 110 kg.

In accordance with the harmonised European Standard EN 474-5, hydraulic excavators used for lifting operations must be equipped with pipe fracture safety valves, an overload warning device, a load lift hook and a lift capacity chart.

Lift Capacities

with Mono Boom 5.00 m, EW-Undercarriage

Stick 2.25 m

m	Undercarriage stabilized		3.0 m		4.5 m		6.0 m		7.5 m		m	
	rear	front	rear	front	rear	front	rear	front	rear	front		
7.5	Blade	—	—	—	2.6*	2.6*	—	—	—	—	2.4*	2.4*
	Outriggers	Blade	—	—	2.6*	2.6*	—	—	—	—	2.4*	2.4*
6.0	Blade	—	—	—	4.0*	4.0*	2.3*	2.3*	—	—	2.1*	2.1*
	Outriggers	Blade	—	—	4.0*	4.0*	2.3*	2.3*	—	—	2.1*	2.1*
4.5	Blade	—	—	—	4.6*	4.6*	2.9*	4.1*	—	—	2.1*	2.1*
	Outriggers	Blade	—	—	4.6*	4.6*	3.3*	4.1*	—	—	2.1*	2.1*
3.0	Blade	—	7.8	8.7*	4.3	5.7*	2.8	4.3	—	—	2.0	2.2*
	Outriggers	Blade	8.7*	8.7*	4.8	5.7*	3.1	4.6*	—	—	2.2*	2.2*
1.5	Blade	—	6.1*	6.1*	3.9	6.3	2.6	4.1	—	—	1.9	2.4*
	Outriggers	Blade	6.1*	6.1*	4.4	6.8*	2.9	5.1*	—	—	2.1	2.4*
0	Blade	—	6.6	7.0*	3.7	6.0	2.5	3.9	—	—	1.9	2.8*
	Outriggers	Blade	7.0*	7.0*	4.2	7.3*	2.8	5.4*	—	—	2.2	2.8*
-1.5	Blade	—	6.6	10.1*	3.6	5.9	2.4	3.9	—	—	2.1	3.4
	Outriggers	Blade	10.1*	10.1*	6.4	7.2*	4.2	5.2*	—	—	3.6*	3.6*
-3.0	Blade	—	6.8	8.9*	3.7	6.0	—	—	—	—	2.7	4.3
	Outriggers	Blade	8.9*	8.9*	6.2*	6.2*	—	—	—	—	3.1	4.7*
-4.5	Blade	—	—	—	—	—	—	—	—	—	—	—
	Outriggers	Blade	—	—	—	—	—	—	—	—	—	—

Stick 2.45 m

m	Undercarriage stabilized		3.0 m		4.5 m		6.0 m		7.5 m		m	
	rear	front	rear	front	rear	front	rear	front	rear	front		
7.5	Blade	—	—	—	3.0*	3.0*	—	—	—	—	2.2*	2.2*
	Outriggers	Blade	—	—	3.0*	3.0*	—	—	—	—	2.2*	2.2*
6.0	Blade	—	—	—	3.7*	3.7*	2.7*	2.7*	—	—	1.9*	1.9*
	Outriggers	Blade	—	—	3.7*	3.7*	2.7*	2.7*	—	—	1.9*	1.9*
4.5	Blade	—	—	—	4.3*	4.3*	2.9	4.0*	—	—	1.9*	1.9*
	Outriggers	Blade	—	—	4.3*	4.3*	3.3	4.0*	—	—	1.9*	1.9*
3.0	Blade	—	8.0	8.1*	4.3	5.5*	2.8	4.3	1.9	2.0*	1.9	2.0*
	Outriggers	Blade	8.1*	8.1*	4.8	5.5*	3.1	4.5*	2.0*	2.0*	2.0*	2.0*
1.5	Blade	—	6.9	7.0*	3.9	6.3	2.6	4.1	1.9	2.7*	1.8	2.1*
	Outriggers	Blade	7.0*	7.0*	4.4	6.6*	2.9	5.0*	2.1	2.7*	2.0	2.1*
0	Blade	—	6.6	7.1*	3.7	6.0	2.5	3.9	—	—	1.8	2.5*
	Outriggers	Blade	7.1*	7.1*	4.2	7.3*	2.8	5.3*	—	—	2.1	2.5*
-1.5	Blade	—	6.6	9.7*	3.6	5.9	2.4	3.9	—	—	2.0	3.2*
	Outriggers	Blade	9.7*	9.7*	6.4	7.2*	4.2	5.2*	—	—	3.2*	3.2*
-3.0	Blade	—	6.7	9.2*	3.6	5.9	—	—	—	—	2.5	4.0
	Outriggers	Blade	9.2*	9.2*	6.4*	6.4*	—	—	—	—	2.9	4.6*
-4.5	Blade	—	—	—	—	—	—	—	—	—	—	—
	Outriggers	Blade	—	—	—	—	—	—	—	—	—	—

Stick 2.65 m

m	Undercarriage stabilized		3.0 m		4.5 m		6.0 m		7.5 m		m	
	rear	front	rear	front	rear	front	rear	front	rear	front		
7.5	Blade	—	—	—	3.1*	3.1*	—	—	—	—	2.0*	2.0*
	Outriggers	Blade	—	—	3.1*	3.1*	—	—	—	—	2.0*	2.0*
6.0	Blade	—	—	—	—	—	2.9*	2.9*	—	—	1.8*	1.8*
	Outriggers	Blade	—	—	—	—	2.9*	2.9*	—	—	1.8*	1.8*
4.5	Blade	—	—	—	4.1*	4.1*	2.9	3.8*	—	—	1.7*	1.7*
	Outriggers	Blade	—	—	4.1*	4.1*	3.3	3.8*	—	—	1.7*	1.7*
3.0	Blade	—	7.6*	7.6*	4.3	5.2*	2.8	4.3	1.9	2.5*	1.8*	1.8*
	Outriggers	Blade	7.6*	7.6*	5.2*	5.2*	4.3*	4.3*	2.5*	2.5*	1.8*	1.8*
1.5	Blade	—	7.0	8.0*	3.9	6.3	2.6	4.1	1.8	2.9	1.7	1.9*
	Outriggers	Blade	8.0*	8.0*	4.4	6.5*	2.9	4.9*	2.1	3.2*	1.9*	1.9*
0	Blade	—	6.6	7.2*	3.6	6.0	2.4	3.9	1.8	2.7*	1.7	2.2*
	Outriggers	Blade	7.2*	7.2*	4.1	7.2*	2.8	5.2*	2.0	2.7*	2.0	2.2*
-1.5	Blade	—	6.5	9.4*	3.5	5.8	2.4	3.8	—	—	1.9	2.8*
	Outriggers	Blade	9.4*	9.4*	6.4	7.2*	4.1	5.2*	—	—	2.2	2.8*
-3.0	Blade	—	6.6	9.4*	3.5	5.9	2.4	3.9	—	—	2.3	3.8
	Outriggers	Blade	9.4*	9.4*	6.4	6.5*	4.2	4.6*	—	—	2.7	4.1*
-4.5	Blade	—	—	—	—	—	—	—	—	—	3.8	4.5*
	Outriggers	Blade	—	—	—	—	—	—	—	—	4.3	4.5*

Height
 Can be slewed through 360°
 In longitudinal position of undercarriage
 Max. reach
 * Limited by hydr. capacity

The lift capacities on the load lift hook of the Liebherr quick coupler SWA 33 without attachment are stated in metric tons (t) and are valid on a firm, level supporting surface with blocked oscillating axle. These capacities can be slewed through 360° with the undercarriage in the transverse position. Capacities in the longitudinal position of the undercarriage (+/- 15°) are specified over the steering axle with the stabilizers raised and over the rigid axle with the stabilizers down. Indicated loads based on the ISO 10567 standard and do not exceed 75 % of tipping or 87 % of hydraulic capacity, or are limited by the permissible load of the load lift hook on the quick coupler (max. 5 t). Without the quick coupler, lift capacities will increase by up to 110 kg.

In accordance with the harmonised European Standard EN 474-5, hydraulic excavators used for lifting operations must be equipped with pipe fracture safety valves, an overload warning device, a load lift hook and a lift capacity chart.

Backhoe Bucket

with Offset Two-Piece Boom 5.00 m

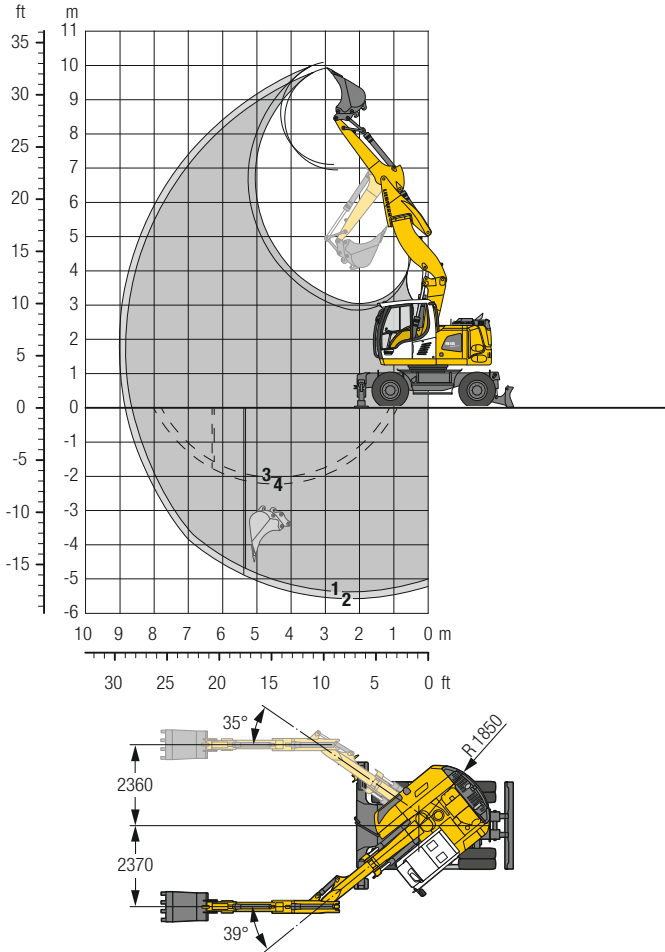

Digging Envelope

with quick coupler	1	2
Stick length	m 2.25	2.45
Max. digging depth	m 5.40	5.60
Max. reach at ground level	m 8.65	8.85
Max. dumping height	m 6.95	7.10
Max. teeth height	m 9.95	10.10
Min. equipment radius	m 2.42	2.48

1 with stick 2.25 m
 2 with stick 2.45 m
 with set straight boom

3 with stick 2.25 m
 4 with stick 2.45 m
 at max. equipment offset
 with vertical ditch walls

Digging Forces

without quick coupler	1	2
Max. digging force (ISO 6015)	kN 81.0	76.0
	t 8.3	7.7
Max. breakout force (ISO 6015)	kN 98.4	98.4
	t 10.0	10.0

Max. breakout force with ripper bucket 125.7 kN (12.8 t)

Operating Weight

The operating weight includes the basic machine with 8 tyres plus intermediate rings, offset two-piece boom 5.00 m, stick 2.45 m, quick coupler SWA 33 and bucket 850 mm / 0.60 m³.

Undercarriage versions	Weight (kg)
A 918 Compact Litronic with rear blade	18,300
A 918 Compact Litronic with rear outriggers + front blade	19,200
A 918 Compact EW Litronic with rear blade	18,400
A 918 Compact EW Litronic with rear outriggers + front blade	19,300

Buckets Machine stability per ISO 10567* (75% of tipping capacity)

Cutting width mm	Capacity ISO 7451 ¹⁾ m ³	Weight kg	Stabilizers raised		Rear blade down		Rear outriggers + front blade down		EW Stabilizers raised		EW Rear blade down		EW Rear outriggers + front blade down	
			Stick length (m)		Stick length (m)		Stick length (m)		Stick length (m)		Stick length (m)		Stick length (m)	
			2.25	2.45	2.25	2.45	2.25	2.45	2.25	2.45	2.25	2.45	2.25	2.45
650 ²⁾	0.42	350	■	■	■	■	■	■	■	■	■	■	■	■
850 ²⁾	0.60	400	■	■	■	■	■	■	■	■	■	■	■	■
1,050 ²⁾	0.80	480	■	△	■	■	■	■	■	■	■	■	■	■
1,250 ²⁾	0.95	530	△	—	△	△	■	■	△	△	■	■	■	■
650 ³⁾	0.42	360	■	■	■	■	■	■	■	■	■	■	■	■
850 ³⁾	0.60	420	■	■	■	■	■	■	■	■	■	■	■	■
1,050 ³⁾	0.80	500	■	△	■	■	■	■	■	■	■	■	■	■
1,250 ³⁾	0.95	550	△	—	△	△	■	■	△	△	■	■	■	■
650 ⁴⁾	0.45	330	■	■	■	■	■	■	■	■	■	■	■	■
850 ⁴⁾	0.65	380	■	■	■	■	■	■	■	■	■	■	■	■
1,050 ⁴⁾	0.85	460	△	△	■	■	■	■	■	■	■	■	■	■
1,250 ⁴⁾	1.05	500	—	—	△	△	■	■	△	△	■	■	■	■

* Indicated loads are based on ISO 10567 and do not exceed 75% of tipping or 87% of hydraulic capacity, max. stick length without quick coupler, lifted 360° on firm with blocked oscillating axle

¹⁾ comparable with SAE (heaped)

²⁾ Bucket with teeth ³⁾ Bucket with teeth in HD-version ⁴⁾ Bucket with cutting edge (also available in HD-version)

Max. material weight ■ = ≤ 1.8 t/m³, ■ = ≤ 1.5 t/m³, △ = ≤ 1.2 t/m³, — = not authorised

Lift Capacities

with Offset Two-Piece Boom 5.00 m

Stick 2.25 m

m	Undercarriage stabilized		3.0 m		4.5 m		6.0 m		7.5 m		m		
	rear	front	rear	front	rear	front	rear	front	rear	front			
7.5	—	—			3.1*	3.1*					2.3*	2.3*	4.8
	Blade	—			3.1*	3.1*					2.3*	2.3*	
6.0	Outriggers	Blade			3.1*	3.1*					2.3*	2.3*	6.2
	—	—			4.4	4.7*	2.6	2.7*			2.0*	2.0*	
4.5	Blade	—			4.7*	4.7*	2.7*	2.7*			2.0*	2.0*	7.0
	Outriggers	Blade	6.4*	6.4*	4.3	5.4*	2.6	4.3			1.8	1.9*	
3.0	—	—	6.4*	6.4*	4.7	5.4*	2.9	4.5*			1.9*	1.9*	7.4
	Blade	—	6.4*	6.4*	5.4*	5.4*	4.5	4.5*			1.9*	1.9*	
1.5	Outriggers	Blade	7.3	9.5*	4.2	6.2*	2.6	4.3			1.6	2.0*	7.5
	—	—	8.1	9.5*	4.5	6.2*	2.9	4.8*			1.8	2.0*	
0	Blade	—	9.5*	9.5*	6.2*	6.2*	4.4	4.8*			2.0*	2.0*	7.3
	Outriggers	Blade	7.1	10.3*	4.1	6.3	2.5	4.2	1.5	2.4*	1.5	2.1*	
-1.5	—	—	7.9	10.3*	4.5	6.8*	2.8	5.0*	1.7	2.4*	1.7	2.1*	6.8
	Blade	—	10.3*	10.3*	6.4	6.8*	4.3	5.0*	2.4*	2.4*	2.1*	2.1*	
-3.0	Outriggers	Blade	11.0*	11.0*	6.5	7.0*	4.1	5.1*			2.4*	2.4*	5.8
	—	—	6.6	11.3*	3.5	6.3	2.1	3.8			1.6	3.0*	
-4.5	Blade	—	7.6	11.3*	4.0	7.2*	2.4	5.0*			1.9	3.0*	7.0
	Outriggers	Blade	11.3*	11.3*	6.5	7.2*	3.9	5.0*			3.0*	3.0*	

Stick 2.45 m

m	Undercarriage stabilized		3.0 m		4.5 m		6.0 m		7.5 m		m		
	rear	front	rear	front	rear	front	rear	front	rear	front			
7.5	—	—			3.3*	3.3*					2.0*	2.0*	5.1
	Blade	—			3.3*	3.3*					2.0*	2.0*	
6.0	Outriggers	Blade			3.3*	3.3*					2.0*	2.0*	6.4
	—	—			4.3*	4.3*	2.6	3.1*			1.8*	1.8*	
4.5	Blade	—			4.3*	4.3*	2.9	3.1*			1.8*	1.8*	7.2
	Outriggers	Blade	5.4*	5.4*	4.3	5.2*	2.7	4.3			1.7	1.7*	
3.0	—	—	5.4*	5.4*	4.7	5.2*	3.0	4.4*			1.7*	1.7*	7.6
	Blade	—	5.4*	5.4*	5.2*	5.2*	4.4*	4.4*			1.7*	1.7*	
1.5	Outriggers	Blade	7.3	9.1*	4.1	6.0*	2.7	4.3	1.6	2.4*	1.5	1.8*	7.7
	—	—	8.1	9.1*	4.5	6.0*	3.0	4.7*	1.8	2.4*	1.7	1.8*	
0	Blade	—	9.1*	9.1*	6.0*	6.0*	4.4	4.7*	2.4*	2.4*	1.8*	1.8*	7.5
	Outriggers	Blade	7.1	10.3*	4.1	6.2	2.5	4.2	1.5	2.8	1.4	1.9*	
-1.5	—	—	7.8	10.3*	4.4	6.7*	2.8	5.0*	1.7	3.2*	1.6	1.9*	7.0
	Blade	—	10.3*	10.3*	6.4	6.7*	4.3	5.0*	2.8	3.2*	1.9*	1.9*	
-3.0	Outriggers	Blade	10.9*	10.9*	6.4	6.9*	4.2	5.1*	2.3*	2.3*	2.2*	2.2*	6.0
	—	—	7.2	10.9*	3.9	6.3	2.3	4.0	1.4	2.3*	1.4	2.2*	
-4.5	Blade	—	7.9	10.9*	4.4	6.9*	2.6	5.1*	1.6	2.3*	1.6	2.2*	7.0
	Outriggers	Blade	10.9*	10.9*	6.4	6.9*	4.2	5.1*	2.3*	2.3*	2.2*	2.2*	

 Height
  Can be slewed through 360°
  In longitudinal position of undercarriage
  Max. reach
 * Limited by hydr. capacity

The lift capacities on the load lift hook of the Liebherr quick coupler SWA 33 without attachment are stated in metric tons (t) and are valid on a firm, level supporting surface with blocked oscillating axle. These capacities can be slewed through 360° with the undercarriage in the transverse position. Capacities in the longitudinal position of the undercarriage (+/- 15°) are specified over the steering axle with the stabilizers raised and over the rigid axle with the stabilizers down. The values apply when the adjusting cylinder is in the optimal position. Indicated loads based on the ISO 10567 standard and do not exceed 75% of tipping or 87% of hydraulic capacity, or are limited by the permissible load of the load lift hook on the quick coupler (max. 5 t). Without the quick coupler, lift capacities will increase by up to 110 kg.

In accordance with the harmonised European Standard EN 474-5, hydraulic excavators used for lifting operations must be equipped with pipe fracture safety valves, an overload warning device, a load lift hook and a lift capacity chart.

Lift Capacities

with Offset Two-Piece Boom 5.00 m, EW-Undercarriage

Stick 2.25 m

m	Undercarriage stabilized		3.0 m		4.5 m		6.0 m		7.5 m		m	
	rear	front	rear	front	rear	front	rear	front	rear	front		
7.5	—	—			3.1*	3.1*					2.3*	2.3*
	Blade	—			3.1*	3.1*					2.3*	2.3*
6.0	Outriggers	Blade			3.1*	3.1*					2.3*	2.3*
	—	—			4.7*	4.7*	2.7*	2.7*			2.0*	2.0*
4.5	Blade	—			4.7*	4.7*	2.7*	2.7*			2.0*	2.0*
	Outriggers	Blade	6.4*	6.4*	4.7*	4.7*	2.7*	2.7*			2.0*	2.0*
3.0	—	—	6.4*	6.4*	4.7*	4.7*	2.7*	2.7*			1.9*	1.9*
	Blade	—	6.4*	6.4*	5.1*	5.4*	3.3*	4.5*			1.9*	1.9*
1.5	Outriggers	Blade	6.4*	6.4*	5.4*	5.4*	4.5*	4.5*			1.9*	1.9*
	—	—	8.0*	9.5*	4.5*	6.2*	2.9*	4.3*			1.8*	2.0*
0	Blade	—	8.9*	9.5*	5.0*	6.2*	3.2*	4.8*			2.0*	2.0*
	Outriggers	Blade	9.5*	9.5*	6.2*	6.2*	4.5*	4.8*			2.0*	2.0*
-1.5	—	—	7.8*	10.3*	4.5*	6.3*	2.8*	4.2*	1.7*	2.4*	1.7*	2.1*
	Blade	—	8.7*	10.3*	4.9*	6.9*	3.1*	5.1*	1.9*	2.4*	1.9*	2.1*
-3.0	Outriggers	Blade	10.3*	10.3*	6.7*	6.9*	4.5*	5.1*	2.4*	2.4*	2.1*	2.1*
	—	—	8.0*	11.0*	4.3*	6.4*	2.6*	4.0*			1.7*	2.4*
-4.5	Blade	—	8.8*	11.0*	4.9*	7.0*	2.9*	5.1*			1.9*	2.4*
	Outriggers	Blade	11.0*	11.0*	6.7*	7.0*	4.4*	5.1*			2.4*	2.4*
-6.8	—	—	7.5*	11.3*	4.0*	6.4*	2.3*	3.8*			1.9*	3.0*
	Blade	—	8.6*	11.3*	4.5*	7.2*	2.7*	5.0*			2.1*	3.0*
-8.8	Outriggers	Blade	11.3*	11.3*	6.9*	7.2*	4.2*	5.0*			3.0*	3.0*
	—	—	7.1*	11.4*	3.6*	6.0*					2.4*	3.2*
-10.8	Blade	—	8.3*	11.4*	4.1*	6.4*					2.7*	3.2*
	Outriggers	Blade	11.4*	11.4*	6.4*	6.4*					3.2*	3.2*

Stick 2.45 m

m	Undercarriage stabilized		3.0 m		4.5 m		6.0 m		7.5 m		m	
	rear	front	rear	front	rear	front	rear	front	rear	front		
7.5	—	—			3.3*	3.3*					2.0*	2.0*
	Blade	—			3.3*	3.3*					2.0*	2.0*
6.0	Outriggers	Blade			3.3*	3.3*					2.0*	2.0*
	—	—			4.3*	4.3*	2.9*	3.1*			1.8*	1.8*
4.5	Blade	—			4.3*	4.3*	3.1*	3.1*			1.8*	1.8*
	Outriggers	Blade			4.3*	4.3*	3.1*	3.1*			1.8*	1.8*
3.0	—	—	5.4*	5.4*	4.7*	5.2*	3.0*	4.4*			1.7*	1.7*
	Blade	—	5.4*	5.4*	5.2*	5.2*	3.3*	4.4*			1.7*	1.7*
1.5	Outriggers	Blade	5.4*	5.4*	5.2*	5.2*	4.4*	4.4*			1.7*	1.7*
	—	—	8.1*	9.1*	4.5*	6.0*	2.9*	4.3*	1.8*	2.4*	1.7*	1.8*
0	Blade	—	8.9*	9.1*	5.0*	6.0*	3.3*	4.7*	2.0*	2.4*	1.8*	1.8*
	Outriggers	Blade	9.1*	9.1*	6.0*	6.0*	4.5*	4.7*	2.4*	2.4*	1.8*	1.8*
-1.5	—	—	7.8*	10.3*	4.4*	6.3*	2.8*	4.3*	1.7*	2.8*	1.6*	1.9*
	Blade	—	8.6*	10.3*	4.8*	6.8*	3.1*	5.0*	1.9*	3.2*	1.8*	1.9*
-3.0	Outriggers	Blade	10.3*	10.3*	6.6*	6.8*	4.5*	5.0*	3.0*	3.2*	1.9*	1.9*
	—	—	7.9*	10.9*	4.4*	6.3*	2.6*	4.1*	1.6*	2.3*	1.6*	2.2*
-4.5	Blade	—	8.7*	10.9*	4.9*	6.9*	2.9*	5.1*	1.8*	2.3*	1.8*	2.2*
	Outriggers	Blade	10.9*	10.9*	6.7*	6.9*	4.4*	5.1*	2.3*	2.3*	2.2*	2.2*
-6.0	—	—	7.5*	11.2*	4.0*	6.4*	2.4*	3.9*			1.8*	2.7*
	Blade	—	8.6*	11.2*	4.6*	7.1*	2.7*	5.1*			2.0*	2.7*
-7.5	Outriggers	Blade	11.2*	11.2*	7.0*	7.1*	4.2*	5.1*			2.7*	2.7*
	—	—	7.2*	11.7*	3.6*	6.0*	2.2*	3.2*			2.2*	3.2*
-9.0	Blade	—	8.3*	11.7*	4.1*	6.8*	2.6*	3.2*			2.5*	3.2*
	Outriggers	Blade	11.7*	11.7*	6.6*	6.8*	3.2*	3.2*			3.2*	3.2*

Height **Can be slewed through 360°** **In longitudinal position of undercarriage** **Max. reach** * **Limited by hydr. capacity**

The lift capacities on the load lift hook of the Liebherr quick coupler SWA 33 without attachment are stated in metric tons (t) and are valid on a firm, level supporting surface with blocked oscillating axle. These capacities can be slewed through 360° with the undercarriage in the transverse position. Capacities in the longitudinal position of the undercarriage (+/- 15°) are specified over the steering axle with the stabilizers raised and over the rigid axle with the stabilizers down. The values apply when the adjusting cylinder is in the optimal position. Indicated loads based on the ISO 10567 standard and do not exceed 75% of tipping or 87% of hydraulic capacity, or are limited by the permissible load of the load lift hook on the quick coupler (max. 5 t). Without the quick coupler, lift capacities will increase by up to 110 kg.

In accordance with the harmonised European Standard EN 474-5, hydraulic excavators used for lifting operations must be equipped with pipe fracture safety valves, an overload warning device, a load lift hook and a lift capacity chart.

Backhoe Bucket

with Offset Mono Boom 4.90 m

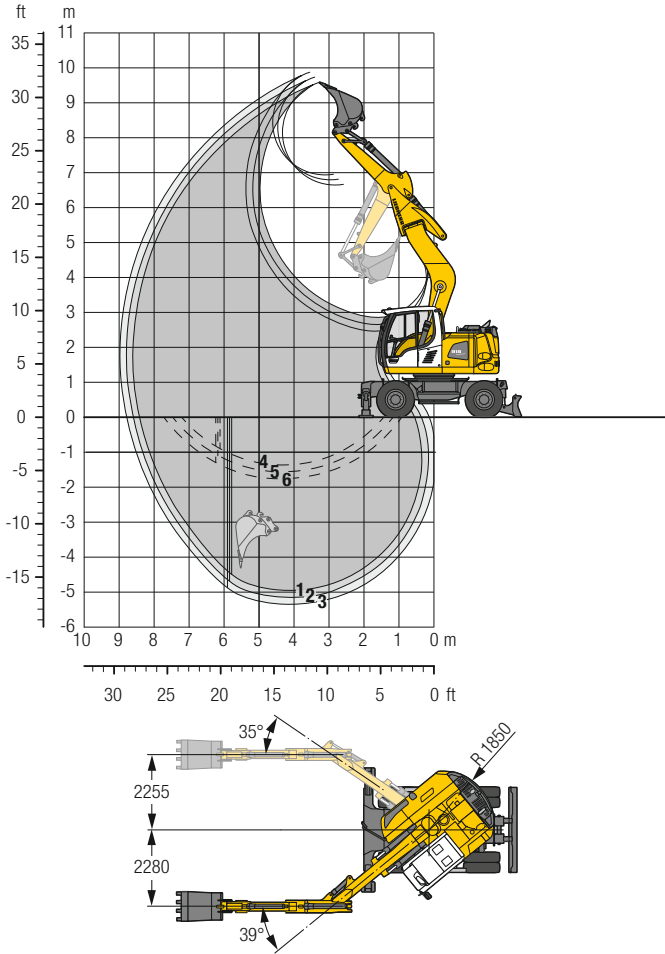

Digging Envelope

with quick coupler		1	2	3
Stick length	m	2.25	2.45	2.65
Max. digging depth	m	4.95	5.15	5.35
Max. reach at ground level	m	8.40	8.60	8.80
Max. dumping height	m	6.65	6.80	6.95
Max. teeth height	m	9.60	9.75	9.85
Min. equipment radius	m	2.07	2.11	2.15

1 with stick 2.25 m
 2 with stick 2.45 m
 3 with stick 2.65 m
 with set straight boom

4 with stick 2.25 m
 5 with stick 2.45 m
 6 with stick 2.65 m
 at max. equipment offset
 with vertical ditch walls

Digging Forces

without quick coupler		1	2	3
Max. digging force (ISO 6015)	kN	81.0	76.0	71.6
	t	8.3	7.7	7.3
Max. breakout force (ISO 6015)	kN	98.4	98.4	98.4
	t	10.0	10.0	10.0

Max. breakout force with ripper bucket 125.7 kN (12.8 t)

Operating Weight

The operating weight includes the basic machine with 8 tyres plus intermediate rings, offset mono boom 4.90 m, stick 2.45 m, quick coupler SWA 33 and bucket 850 mm / 0.60 m³.

Undercarriage versions	Weight (kg)
A 918 Compact Litronic with rear blade	17,800
A 918 Compact Litronic with rear outriggers + front blade	18,700
A 918 Compact EW Litronic with rear blade	17,900
A 918 Compact EW Litronic with rear outriggers + front blade	18,800

Buckets Machine stability per ISO 10567* (75% of tipping capacity)

Cutting width mm	Capacity ISO 7451 ¹⁾ m ³	Weight kg	Stabilizers raised			Rear blade down			Rear outriggers + front blade down			EW Stabilizers raised			EW Rear blade down			EW Rear outriggers + front blade down		
			Stick length (m)			Stick length (m)			Stick length (m)			Stick length (m)			Stick length (m)			Stick length (m)		
			2.25	2.45	2.65	2.25	2.45	2.65	2.25	2.45	2.65	2.25	2.45	2.65	2.25	2.45	2.65	2.25	2.45	2.65
650 ²⁾	0.42	350	■	■	■	■	■	■	■	■	■	■	■	■	■	■	■	■	■	■
850 ²⁾	0.60	400	■	■	■	■	■	■	■	■	■	■	■	■	■	■	■	■	■	■
1,050 ²⁾	0.80	480	■	■	■	■	■	■	■	■	■	■	■	■	■	■	■	■	■	■
1,250 ²⁾	0.95	530	△	△	△	■	■	△	■	■	■	■	■	△	■	■	■	■	■	■
650 ³⁾	0.42	360	■	■	■	■	■	■	■	■	■	■	■	■	■	■	■	■	■	■
850 ³⁾	0.60	420	■	■	■	■	■	■	■	■	■	■	■	■	■	■	■	■	■	■
1,050 ³⁾	0.80	500	■	■	△	■	■	■	■	■	■	■	■	■	■	■	■	■	■	■
1,250 ³⁾	0.95	550	△	△	△	■	■	△	■	■	■	■	■	△	■	■	■	■	■	■
650 ⁴⁾	0.45	330	■	■	■	■	■	■	■	■	■	■	■	■	■	■	■	■	■	■
850 ⁴⁾	0.65	380	■	■	■	■	■	■	■	■	■	■	■	■	■	■	■	■	■	■
1,050 ⁴⁾	0.85	460	■	■	△	■	■	■	■	■	■	■	■	■	■	■	■	■	■	■
1,250 ⁴⁾	1.05	500	△	△	-	■	△	△	■	■	■	△	△	△	■	■	■	■	■	■

* Indicated loads are based on ISO 10567 and do not exceed 75% of tipping or 87% of hydraulic capacity, max. stick length without quick coupler, lifted 360° on firm with blocked oscillating axle

¹⁾ comparable with SAE (heaped)

²⁾ Bucket with teeth ³⁾ Bucket with teeth in HD-version ⁴⁾ Bucket with cutting edge (also available in HD-version)

Max. material weight ■ = ≤ 1.8 t/m³, ■ = ≤ 1.5 t/m³, △ = ≤ 1.2 t/m³, - = not authorised

Lift Capacities

with Offset Mono Boom 4.90 m

Stick 2.25 m

m	Undercarriage stabilized		3.0 m		4.5 m		6.0 m		7.5 m		m	
	rear	front	rear	front	rear	front	rear	front	rear	front	rear	front
7.5	Blade	—									2.2*	2.2*
	Outriggers	Blade									2.2*	2.2*
6.0	Blade	—			4.3*	4.3*					2.0*	2.0*
	Outriggers	Blade			4.3*	4.3*					2.0*	2.0*
4.5	Blade	—	5.9*	5.9*	4.1	4.8*	2.5	4.1*			1.9*	1.9*
	Outriggers	Blade	5.9*	5.9*	4.8*	4.8*	4.1*	4.1*			1.9*	1.9*
3.0	Blade	—	6.8	8.7*	3.7	5.8*	2.4	4.1			1.7	2.0*
	Outriggers	Blade	7.7	8.7*	4.2	5.8*	2.7	4.6*			2.0	2.0*
1.5	Blade	—	5.7	7.6*	3.3	6.0	2.2	3.9			1.6	2.2*
	Outriggers	Blade	6.6	7.6*	3.7	6.7*	2.5	5.0*			1.8	2.2*
0	Blade	—	5.3	8.0*	3.0	5.7	2.0	3.8			1.6	2.6*
	Outriggers	Blade	6.2	8.0*	3.5	7.1*	2.3	5.2*			1.9	2.6*
-1.5	Blade	—	8.0*	8.0*	5.9	7.1*	3.9	5.2*			2.6*	2.6*
	Outriggers	Blade	5.4	9.8*	2.9	5.6	2.0	3.7			1.8	3.3
-3.0	Blade	—	6.3	9.8*	3.4	6.8*	2.3	4.9*			2.1	3.5*
	Outriggers	Blade	9.8*	9.8*	5.8	6.8*	3.8	4.9*			3.5	3.5*
-4.5	Blade	—	5.6	7.8*	3.0	5.5*					2.4	4.4*
	Outriggers	Blade	6.5	7.8*	3.5	5.5*					2.7	4.4*

Stick 2.45 m

m	Undercarriage stabilized		3.0 m		4.5 m		6.0 m		7.5 m		m	
	rear	front	rear	front	rear	front	rear	front	rear	front	rear	front
7.5	Blade	—			2.4*	2.4*					2.0*	2.0*
	Outriggers	Blade			2.4*	2.4*					2.0*	2.0*
6.0	Blade	—			4.1*	4.1*	2.1*	2.1*			1.8*	1.8*
	Outriggers	Blade			4.1*	4.1*	2.1*	2.1*			1.8*	1.8*
4.5	Blade	—			4.2	4.6*	2.6	4.0*			1.7*	1.7*
	Outriggers	Blade			4.6*	4.6*	2.9	4.0*			1.7*	1.7*
3.0	Blade	—	6.9	8.3*	3.7	5.6*	2.4	4.1			1.7	1.8*
	Outriggers	Blade	7.9	8.3*	4.2	5.6*	2.7	4.5*			1.8*	1.8*
1.5	Blade	—	8.3*	8.3*	5.6*	5.6*	4.3	4.5*			1.8*	1.8*
	Outriggers	Blade	5.7	8.7*	3.3	6.1	2.2	3.9			1.5	2.0*
0	Blade	—	6.6	8.7*	3.8	6.6*	2.5	4.9*			1.8	2.0*
	Outriggers	Blade	8.7*	8.7*	6.3	6.6*	4.0	4.9*			2.0*	2.0*
-1.5	Blade	—	5.3	8.1*	3.0	5.7	2.0	3.7			1.5	2.4*
	Outriggers	Blade	6.2	8.1*	3.5	7.0*	2.3	5.1*			1.8	2.4*
-3.0	Blade	—	8.1*	8.1*	5.9	7.0*	3.9	5.1*			2.4*	2.4*
	Outriggers	Blade	5.3	10.0*	2.9	5.6	2.0	3.7			1.7	3.1*
-4.5	Blade	—	6.2	10.0*	3.4	6.8*	2.3	4.9*			2.0	3.1*
	Outriggers	Blade	10.0*	10.0*	5.8	6.8*	3.8	4.9*			3.1*	3.1*
-3.0	Blade	—	5.5	8.1*	3.0	5.7					2.2	4.1
	Outriggers	Blade	6.4	8.1*	3.4	5.7*					2.5	4.3*

Stick 2.65 m

m	Undercarriage stabilized		3.0 m		4.5 m		6.0 m		7.5 m		m	
	rear	front	rear	front	rear	front	rear	front	rear	front	rear	front
7.5	Blade	—			2.7*	2.7*					1.8*	1.8*
	Outriggers	Blade			2.7*	2.7*					1.8*	1.8*
6.0	Blade	—			3.9*	3.9*	2.4*	2.4*			1.6*	1.6*
	Outriggers	Blade			3.9*	3.9*	2.4*	2.4*			1.6*	1.6*
4.5	Blade	—			4.2	4.4*	2.6	3.9*			1.6*	1.6*
	Outriggers	Blade			4.4*	4.4*	2.9	3.9*			1.6*	1.6*
3.0	Blade	—	7.1	7.8*	3.8	5.4*	2.4	4.1	1.6	1.8*	1.6	1.6*
	Outriggers	Blade	7.8*	7.8*	4.3	5.4*	4.3	4.4*	1.8*	1.8*	1.6*	1.6*
1.5	Blade	—	5.8	9.9*	3.3	6.1	2.2	3.9	1.5	2.5*	1.5	1.8*
	Outriggers	Blade	6.7	9.9*	3.8	6.4*	2.5	4.8*	1.7	2.5*	1.7	1.8*
0	Blade	—	9.9*	9.9*	6.3	6.4*	4.0	4.8*	2.5*	2.5*	1.8*	1.8*
	Outriggers	Blade	5.3	8.2*	3.0	5.7	2.0	3.7			1.5	2.1*
-1.5	Blade	—	6.2	8.2*	3.4	7.0*	2.3	5.1*			1.7	2.1*
	Outriggers	Blade	8.2*	8.2*	5.9	7.0*	3.9	5.1*			2.1*	2.1*
-3.0	Blade	—	5.2	10.2*	2.9	5.6	1.9	3.6			1.6	2.7*
	Outriggers	Blade	6.1	10.2*	3.3	6.8*	2.2	5.0*			1.8	2.7*
-4.5	Blade	—	5.4	8.5*	2.9	5.6					2.0	3.8
	Outriggers	Blade	6.3	8.5*	3.4	5.9*					2.3	4.1*

Height Can be slewed through 360° In longitudinal position of undercarriage Max. reach * Limited by hydr. capacity

The lift capacities on the load lift hook of the Liebherr quick coupler SWA 33 without attachment are stated in metric tons (t) and are valid on a firm, level supporting surface with blocked oscillating axle. These capacities can be slewed through 360° with the undercarriage in the transverse position. Capacities in the longitudinal position of the undercarriage (+/- 15°) are specified over the steering axle with the stabilizers raised and over the rigid axle with the stabilizers down. Indicated loads based on the ISO 10567 standard and do not exceed 75% of tipping or 87% of hydraulic capacity, or are limited by the permissible load of the load lift hook on the quick coupler (max. 5 t). Without the quick coupler, lift capacities will increase by up to 110 kg.

In accordance with the harmonised European Standard EN 474-5, hydraulic excavators used for lifting operations must be equipped with pipe fracture safety valves, an overload warning device, a load lift hook and a lift capacity chart.

Lift Capacities

with Offset Mono Boom 4.90 m, EW-Undercarriage

Stick 2.25 m

m	Undercarriage stabilized		3.0 m		4.5 m		6.0 m		7.5 m		m	
	rear	front										
7.5	Blade	—	—	—	—	—	—	—	—	—	2.2*	2.2*
	Outriggers	Blade	—	—	—	—	—	—	—	—	2.2*	2.2*
6.0	Blade	—	—	—	4.3*	4.3*	—	—	—	—	2.0*	2.0*
	Outriggers	Blade	—	—	4.3*	4.3*	—	—	—	—	2.0*	2.0*
4.5	Blade	—	5.9*	5.9*	4.6	4.8*	2.8	4.1*	—	—	1.9*	1.9*
	Outriggers	Blade	5.9*	5.9*	4.8*	4.8*	3.2	4.1*	—	—	1.9*	1.9*
3.0	Blade	—	7.7	8.7*	4.1	5.8*	2.7	4.1	—	—	2.0	2.0*
	Outriggers	Blade	8.7*	8.7*	4.7	5.8*	3.0	4.6*	—	—	2.0*	2.0*
1.5	Blade	—	6.5	7.6*	3.7	6.1	2.5	3.9	—	—	1.8	2.2*
	Outriggers	Blade	7.6*	7.6*	4.2	6.7*	2.8	5.0*	—	—	2.1	2.2*
0	Blade	—	6.2	8.0*	3.4	5.8	2.3	3.8	—	—	1.8	2.6*
	Outriggers	Blade	8.0*	8.0*	3.9	7.1*	2.6	5.2*	—	—	2.1	2.6*
-1.5	Blade	—	6.2	9.8*	3.4	5.7	2.3	3.7	—	—	2.1	3.4
	Outriggers	Blade	9.8*	9.8*	6.2	6.8*	4.0	4.9*	—	—	2.4	3.5*
-3.0	Blade	—	6.4	7.8*	3.4	5.5*	—	—	—	—	2.7	4.4*
	Outriggers	Blade	7.5	7.8*	3.9	5.5*	—	—	—	—	3.1	4.4*
-4.5	Blade	—	—	—	—	—	—	—	—	—	—	—
	Outriggers	Blade	—	—	—	—	—	—	—	—	—	—

Stick 2.45 m

m	Undercarriage stabilized		3.0 m		4.5 m		6.0 m		7.5 m		m	
	rear	front										
7.5	Blade	—	—	—	—	—	—	—	—	—	2.0*	2.0*
	Outriggers	Blade	—	—	—	—	—	—	—	—	2.0*	2.0*
6.0	Blade	—	—	—	—	—	—	—	—	—	1.8*	1.8*
	Outriggers	Blade	—	—	—	—	—	—	—	—	1.8*	1.8*
4.5	Blade	—	—	—	—	—	—	—	—	—	1.7*	1.7*
	Outriggers	Blade	—	—	—	—	—	—	—	—	1.7*	1.7*
3.0	Blade	—	7.9	8.3*	4.2	5.6*	2.7	4.2	—	—	1.8*	1.8*
	Outriggers	Blade	8.3*	8.3*	4.7	5.6*	3.0	4.5*	—	—	1.8*	1.8*
1.5	Blade	—	6.6	8.7*	3.7	6.1	2.5	3.9	—	—	1.7	2.0*
	Outriggers	Blade	8.7*	8.7*	6.6*	6.6*	4.3	4.9*	—	—	2.0	2.0*
0	Blade	—	6.2	8.1*	3.4	5.8	2.3	3.8	—	—	1.8	2.4*
	Outriggers	Blade	8.1*	8.1*	3.9	7.0*	2.6	5.1*	—	—	2.0	2.4*
-1.5	Blade	—	6.1	10.0*	3.3	5.6	2.2	3.7	—	—	1.9	3.1*
	Outriggers	Blade	10.0*	10.0*	6.2	6.8*	4.0	4.9*	—	—	2.2	3.1*
-3.0	Blade	—	6.3	8.1*	3.4	5.7	—	—	—	—	2.5	4.1
	Outriggers	Blade	7.4	8.1*	3.9	5.7*	—	—	—	—	2.8	4.3*
-4.5	Blade	—	—	—	—	—	—	—	—	—	—	—
	Outriggers	Blade	—	—	—	—	—	—	—	—	—	—

Stick 2.65 m

m	Undercarriage stabilized		3.0 m		4.5 m		6.0 m		7.5 m		m	
	rear	front										
7.5	Blade	—	—	—	2.7*	2.7*	—	—	—	—	1.8*	1.8*
	Outriggers	Blade	—	—	2.7*	2.7*	—	—	—	—	1.8*	1.8*
6.0	Blade	—	—	—	—	—	—	—	—	—	1.6*	1.6*
	Outriggers	Blade	—	—	—	—	—	—	—	—	1.6*	1.6*
4.5	Blade	—	—	—	—	—	—	—	—	—	1.6*	1.6*
	Outriggers	Blade	—	—	—	—	—	—	—	—	1.6*	1.6*
3.0	Blade	—	7.8*	7.8*	4.2	5.4*	2.7	4.2	1.8	1.8*	1.6*	1.6*
	Outriggers	Blade	7.8*	7.8*	5.4*	5.4*	4.4*	4.4*	1.8*	1.8*	1.6*	1.6*
1.5	Blade	—	6.7	9.9*	3.7	6.1	2.4	3.9	1.7	2.5*	1.7	1.8*
	Outriggers	Blade	7.7	9.9*	4.3	6.4*	2.8	4.8*	2.0	2.5*	1.8*	1.8*
0	Blade	—	6.1	8.2*	3.4	5.8	2.3	3.8	—	—	1.7	2.1*
	Outriggers	Blade	8.2*	8.2*	3.9	7.0*	2.6	5.1*	—	—	1.9	2.1*
-1.5	Blade	—	6.1	10.2*	3.3	5.6	2.2	3.7	—	—	1.8	2.7*
	Outriggers	Blade	10.2*	10.2*	6.1	6.8*	4.0	5.0*	—	—	2.1	2.7*
-3.0	Blade	—	6.2	8.5*	3.3	5.7	—	—	—	—	2.3	3.8
	Outriggers	Blade	7.3	8.5*	3.8	5.9*	—	—	—	—	2.6	4.1*
-4.5	Blade	—	—	—	—	—	—	—	—	—	—	—
	Outriggers	Blade	—	—	—	—	—	—	—	—	—	—

Height Can be slewed through 360° In longitudinal position of undercarriage Max. reach * Limited by hydr. capacity

The lift capacities on the load lift hook of the Liebherr quick coupler SWA 33 without attachment are stated in metric tons (t) and are valid on a firm, level supporting surface with blocked oscillating axle. These capacities can be slewed through 360° with the undercarriage in the transverse position. Capacities in the longitudinal position of the undercarriage (+/- 15°) are specified over the steering axle with the stabilizers raised and over the rigid axle with the stabilizers down. Indicated loads based on the ISO 10567 standard and do not exceed 75% of tipping or 87% of hydraulic capacity, or are limited by the permissible load of the load lift hook on the quick coupler (max. 5 t). Without the quick coupler, lift capacities will increase by up to 110 kg.

In accordance with the harmonised European Standard EN 474-5, hydraulic excavators used for lifting operations must be equipped with pipe fracture safety valves, an overload warning device, a load lift hook and a lift capacity chart.

Clamshell Grab

with Two-Piece Boom 5.05 m

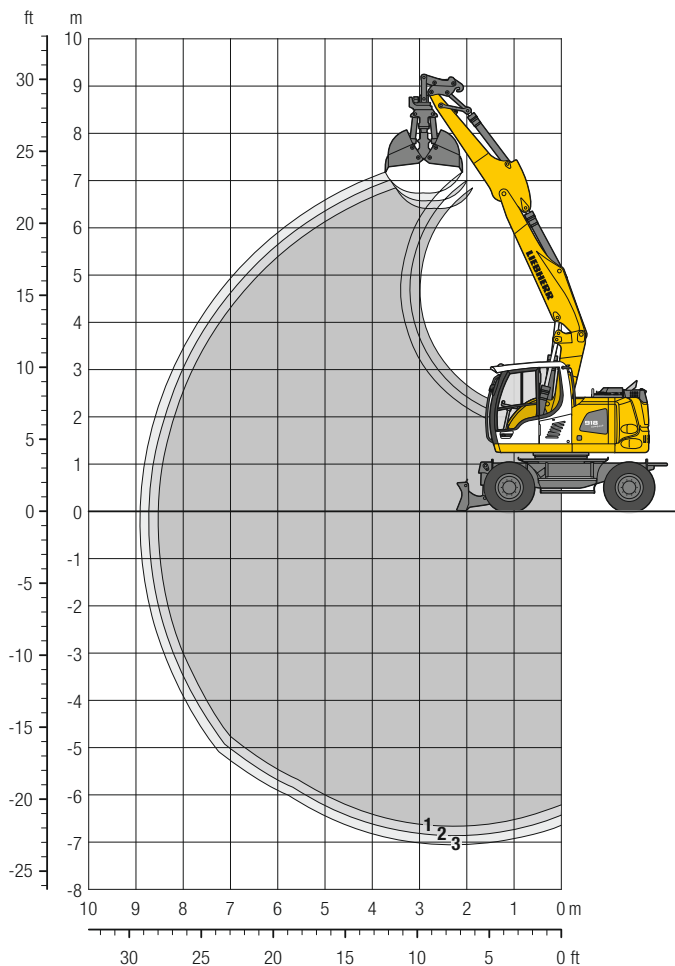

Digging Envelope

with quick coupler	1	2	3
Stick length	m 2.25	2.45	2.65
Max. digging depth	m 6.70	6.90	7.10
Max. reach at ground level	m 8.55	8.75	8.95
Max. dumping height	m 6.40	6.60	6.75

Clamshell Grab GM 10B

Max. tooth force	73 kN (7.4 t)
Max. torque of hydr. swivel	1.76 kNm

Operating Weight

The operating weight includes the basic machine with 8 tyres plus intermediate rings, two-piece boom 5.05 m, stick 2.45 m, quick coupler SWA 33 and clamshell grab GM 10B/0.45 m³ (800 mm without ejector).

Undercarriage versions	Weight (kg)
A 918 Compact Litronic [®] with rear blade	18,200
A 918 Compact Litronic [®] with rear outriggers + front blade	19,100
A 918 Compact EW Litronic [®] with rear blade	18,300
A 918 Compact EW Litronic [®] with rear outriggers + front blade	19,200

Clamshell Grab GM 10B Machine stability per ISO 10567* (75% of tipping capacity)

Width of clamshells mm	Capacity m ³	Weight kg	Stabilizers raised			Rear blade down			Rear outriggers + front blade down			EW Stabilizers raised			EW Rear blade down			EW Rear outriggers + front blade down		
			Stick length (m)			Stick length (m)			Stick length (m)			Stick length (m)			Stick length (m)			Stick length (m)		
			2.25	2.45	2.65	2.25	2.45	2.65	2.25	2.45	2.65	2.25	2.45	2.65	2.25	2.45	2.65	2.25	2.45	2.65
320 ¹⁾	0.17	840	■	■	■	■	■	■	■	■	■	■	■	■	■	■	■	■	■	■
400 ¹⁾	0.22	880	■	■	■	■	■	■	■	■	■	■	■	■	■	■	■	■	■	■
600 ¹⁾	0.35	960	■	■	■	■	■	■	■	■	■	■	■	■	■	■	■	■	■	■
800 ¹⁾	0.45	1,010	■	■	■	■	■	■	■	■	■	■	■	■	■	■	■	■	■	■
1,000 ¹⁾	0.60	1,070	■	■	△	■	■	■	■	■	■	■	■	■	■	■	■	■	■	■
320 ²⁾	0.17	890	■	■	■	■	■	■	■	■	■	■	■	■	■	■	■	■	■	■
400 ²⁾	0.22	940	■	■	■	■	■	■	■	■	■	■	■	■	■	■	■	■	■	■
600 ²⁾	0.35	1,060	■	■	■	■	■	■	■	■	■	■	■	■	■	■	■	■	■	■
800 ²⁾	0.45	1,150	■	■	■	■	■	■	■	■	■	■	■	■	■	■	■	■	■	■

* Indicated loads are based on ISO 10567 and do not exceed 75% of tipping or 87% of hydraulic capacity, max. stick length without quick coupler, lifted 360° on firm with blocked oscillating axle

¹⁾ without ejector

²⁾ with ejector

Max. material weight ■ = ≤ 1.8 t/m³, ■ = ≤ 1.5 t/m³, △ = ≤ 1.2 t/m³, - = not authorised

Clamshell Grab

with Mono Boom 5.00 m

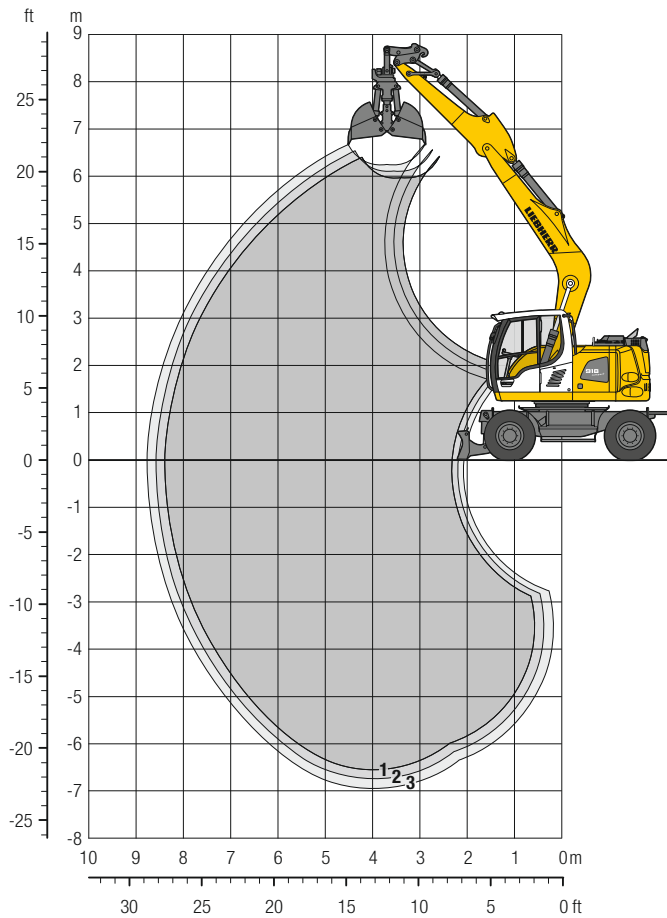

Digging Envelope

with quick coupler	1	2	3
Stick length	m 2.25	2.45	2.65
Max. digging depth	m 6.55	6.75	6.95
Max. reach at ground level	m 8.40	8.60	8.80
Max. dumping height	m 5.95	6.10	6.25

Clamshell Grab GM 10B

Max. tooth force	73 kN (7.4 t)
Max. torque of hydr. swivel	1.76 kNm

Operating Weight

The operating weight includes the basic machine with 8 tyres plus intermediate rings, mono boom 5.00 m, stick 2.45 m, quick coupler SWA 33 and clamshell grab GM 10B/0.45 m³ (800 mm without ejector).

Undercarriage versions	Weight (kg)
A 918 Compact Litronic [®] with rear blade	17,900
A 918 Compact Litronic [®] with rear outriggers + front blade	18,900
A 918 Compact EW Litronic [®] with rear blade	18,000
A 918 Compact EW Litronic [®] with rear outriggers + front blade	19,000

Clamshell Grab GM 10B Machine stability per ISO 10567* (75% of tipping capacity)

Width of clamshells mm	Capacity m ³	Weight kg	Stabilizers raised			Rear blade down			Rear outriggers + front blade down			EW Stabilizers raised			EW Rear blade down			EW Rear outriggers + front blade down		
			Stick length (m)			Stick length (m)			Stick length (m)			Stick length (m)			Stick length (m)			Stick length (m)		
			2.25	2.45	2.65	2.25	2.45	2.65	2.25	2.45	2.65	2.25	2.45	2.65	2.25	2.45	2.65	2.25	2.45	2.65
320 ¹⁾	0.17	840	■	■	■	■	■	■	■	■	■	■	■	■	■	■	■	■	■	■
400 ¹⁾	0.22	880	■	■	■	■	■	■	■	■	■	■	■	■	■	■	■	■	■	■
600 ¹⁾	0.35	960	■	■	■	■	■	■	■	■	■	■	■	■	■	■	■	■	■	■
800 ¹⁾	0.45	1,010	■	■	■	■	■	■	■	■	■	■	■	■	■	■	■	■	■	■
1,000 ¹⁾	0.60	1,070	■	■	△	■	■	■	■	■	■	■	■	■	■	■	■	■	■	■
320 ²⁾	0.17	890	■	■	■	■	■	■	■	■	■	■	■	■	■	■	■	■	■	■
400 ²⁾	0.22	940	■	■	■	■	■	■	■	■	■	■	■	■	■	■	■	■	■	■
600 ²⁾	0.35	1,060	■	■	■	■	■	■	■	■	■	■	■	■	■	■	■	■	■	■
800 ²⁾	0.45	1,150	■	■	■	■	■	■	■	■	■	■	■	■	■	■	■	■	■	■

* Indicated loads are based on ISO 10567 and do not exceed 75% of tipping or 87% of hydraulic capacity, max. stick length without quick coupler, lifted 360° on firm with blocked oscillating axle

¹⁾ without ejector

²⁾ with ejector

Max. material weight ■ = ≤ 1.8 t/m³, ■ = ≤ 1.5 t/m³, △ = ≤ 1.2 t/m³, - = not authorised

Equipments

Clamshell Grabs

Clamshell Grab GM 8B Machine stability per ISO 10567* (75% of tipping capacity)

Width of clamshells mm	Capacity m ³	Weight kg	Stabilizers raised			Rear blade down			Rear outriggers + front blade down			EW Stabilizers raised			EW Rear blade down			EW Rear outriggers + front blade down		
			Stick length (m)			Stick length (m)			Stick length (m)			Stick length (m)			Stick length (m)			Stick length (m)		
			2.25	2.45	2.65	2.25	2.45	2.65	2.25	2.45	2.65	2.25	2.45	2.65	2.25	2.45	2.65	2.25	2.45	2.65
Two-piece boom 5.05 m																				
320 ¹⁾	0.17	815	■	■	■	■	■	■	■	■	■	■	■	■	■	■	■	■	■	■
400 ¹⁾	0.22	860	■	■	■	■	■	■	■	■	■	■	■	■	■	■	■	■	■	■
600 ¹⁾	0.30	850	■	■	■	■	■	■	■	■	■	■	■	■	■	■	■	■	■	■
800 ¹⁾	0.40	900	■	■	■	■	■	■	■	■	■	■	■	■	■	■	■	■	■	■
1,000 ¹⁾³⁾	0.80	1,000	△	-	-	■	△	△	■	■	■	■	■	△	△	■	■	■	■	■
320 ²⁾	0.17	870	■	■	■	■	■	■	■	■	■	■	■	■	■	■	■	■	■	■
400 ²⁾	0.22	920	■	■	■	■	■	■	■	■	■	■	■	■	■	■	■	■	■	■
600 ²⁾	0.30	940	■	■	■	■	■	■	■	■	■	■	■	■	■	■	■	■	■	■
800 ²⁾	0.40	1,010	■	■	■	■	■	■	■	■	■	■	■	■	■	■	■	■	■	■
Mono boom 5.0 m																				
320 ¹⁾	0.17	815	■	■	■	■	■	■	■	■	■	■	■	■	■	■	■	■	■	■
400 ¹⁾	0.22	860	■	■	■	■	■	■	■	■	■	■	■	■	■	■	■	■	■	■
600 ¹⁾	0.30	850	■	■	■	■	■	■	■	■	■	■	■	■	■	■	■	■	■	■
800 ¹⁾	0.40	900	■	■	■	■	■	■	■	■	■	■	■	■	■	■	■	■	■	■
1,000 ¹⁾³⁾	0.80	1,000	△	△	-	■	■	△	■	■	■	■	■	△	△	■	■	■	■	■
320 ²⁾	0.17	870	■	■	■	■	■	■	■	■	■	■	■	■	■	■	■	■	■	■
400 ²⁾	0.22	920	■	■	■	■	■	■	■	■	■	■	■	■	■	■	■	■	■	■
600 ²⁾	0.30	940	■	■	■	■	■	■	■	■	■	■	■	■	■	■	■	■	■	■
800 ²⁾	0.40	1,010	■	■	■	■	■	■	■	■	■	■	■	■	■	■	■	■	■	■
Offset two-piece boom 5.00 m																				
320 ¹⁾	0.17	815	■	■	-	■	■	-	■	■	-	■	■	-	■	■	-	■	■	-
400 ¹⁾	0.22	860	■	■	-	■	■	-	■	■	-	■	■	-	■	■	-	■	■	-
600 ¹⁾	0.30	850	■	■	-	■	■	-	■	■	-	■	■	-	■	■	-	■	■	-
800 ¹⁾	0.40	900	■	■	-	■	■	-	■	■	-	■	■	-	■	■	-	■	■	-
1,000 ¹⁾³⁾	0.80	1,000	-	-	-	△	△	-	■	■	-	△	△	-	■	■	-	■	■	-
320 ²⁾	0.17	870	■	■	-	■	■	-	■	■	-	■	■	-	■	■	-	■	■	-
400 ²⁾	0.22	920	■	■	-	■	■	-	■	■	-	■	■	-	■	■	-	■	■	-
600 ²⁾	0.30	940	■	■	-	■	■	-	■	■	-	■	■	-	■	■	-	■	■	-
800 ²⁾	0.40	1,010	■	■	-	■	■	-	■	■	-	■	■	-	■	■	-	■	■	-
Offset mono boom 4.90 m																				
320 ¹⁾	0.17	815	■	■	■	■	■	■	■	■	■	■	■	■	■	■	■	■	■	■
400 ¹⁾	0.22	860	■	■	■	■	■	■	■	■	■	■	■	■	■	■	■	■	■	■
600 ¹⁾	0.30	850	■	■	■	■	■	■	■	■	■	■	■	■	■	■	■	■	■	■
800 ¹⁾	0.40	900	■	■	■	■	■	■	■	■	■	■	■	■	■	■	■	■	■	■
1,000 ¹⁾³⁾	0.80	1,000	△	-	-	■	△	△	■	■	■	■	■	△	△	△	■	■	■	■
320 ²⁾	0.17	870	■	■	■	■	■	■	■	■	■	■	■	■	■	■	■	■	■	■
400 ²⁾	0.22	920	■	■	■	■	■	■	■	■	■	■	■	■	■	■	■	■	■	■
600 ²⁾	0.30	940	■	■	■	■	■	■	■	■	■	■	■	■	■	■	■	■	■	■
800 ²⁾	0.40	1,010	■	■	■	■	■	■	■	■	■	■	■	■	■	■	■	■	■	■

* Indicated loads are based on ISO 10567 and do not exceed 75% of tipping or 87% of hydraulic capacity, max. stick length without quick coupler, lifted 360° on firm with blocked oscillating axle

¹⁾ without ejector

²⁾ with ejector

³⁾ Shells for loose material

Max. material weight ■ = ≤ 1.8 t/m³, ■ = ≤ 1.5 t/m³, △ = ≤ 1.2 t/m³, - = not authorised

Clamshell Grab GM 10B Machine stability per ISO 10567* (75% of tipping capacity)

Width of clamshells mm	Capacity m ³	Weight kg	Stabilizers raised			Rear blade down			Rear outriggers + front blade down			EW Stabilizers raised			EW Rear blade down			EW Rear outriggers + front blade down		
			Stick length (m)			Stick length (m)			Stick length (m)			Stick length (m)			Stick length (m)			Stick length (m)		
			2.25	2.45	2.65	2.25	2.45	2.65	2.25	2.45	2.65	2.25	2.45	2.65	2.25	2.45	2.65	2.25	2.45	2.65
Offset two-piece boom 5.00 m																				
320 ¹⁾	0.17	840	■	■	-	■	■	-	■	■	-	■	■	-	■	■	-	■	■	-
400 ¹⁾	0.22	880	■	■	-	■	■	-	■	■	-	■	■	-	■	■	-	■	■	-
600 ¹⁾	0.35	960	■	■	-	■	■	-	■	■	-	■	■	-	■	■	-	■	■	-
800 ¹⁾	0.45	1,010	■	■	-	■	■	-	■	■	-	■	■	-	■	■	-	■	■	-
1,000 ¹⁾	0.60	1,070	△	-	-	■	■	-	■	■	-	■	■	-	■	■	-	■	■	-
320 ²⁾	0.17	890	■	■	-	■	■	-	■	■	-	■	■	-	■	■	-	■	■	-
400 ²⁾	0.22	940	■	■	-	■	■	-	■	■	-	■	■	-	■	■	-	■	■	-
600 ²⁾	0.35	1,060	■	■	-	■	■	-	■	■	-	■	■	-	■	■	-	■	■	-
800 ²⁾	0.45	1,150	■	△	-	■	■	-	■	■	-	■	■	-	■	■	-	■	■	-
Offset mono boom 4.90 m																				
320 ¹⁾	0.17	840	■	■	■	■	■	■	■	■	■	■	■	■	■	■	■	■	■	■
400 ¹⁾	0.22	880	■	■	■	■	■	■	■	■	■	■	■	■	■	■	■	■	■	■
600 ¹⁾	0.35	960	■	■	■	■	■	■	■	■	■	■	■	■	■	■	■	■	■	■
800 ¹⁾	0.45	1,010	■	■	■	■	■	■	■	■	■	■	■	■	■	■	■	■	■	■
1,000 ¹⁾	0.60	1,070	■	△	△	■	■	■	■	■	■	■	■	■	■	■	■	■	■	■
320 ²⁾	0.17	890	■	■	■	■	■	■	■	■	■	■	■	■	■	■	■	■	■	■
400 ²⁾	0.22	940	■	■	■	■	■	■	■	■	■	■	■	■	■	■	■	■	■	■
600 ²⁾	0.35	1,060	■	■	■	■	■	■	■	■	■	■	■	■	■	■	■	■	■	■
800 ²⁾	0.45	1,150	■	■	■	■	■	■	■	■	■	■	■	■	■	■	■	■	■	■

* Indicated loads are based on ISO 10567 and do not exceed 75% of tipping or 87% of hydraulic capacity, max. stick length without quick coupler, lifted 360° on firm with blocked oscillating axle

¹⁾ without ejector

²⁾ with ejector

Max. material weight ■ = ≤ 1.8 t/m³, ■ = ≤ 1.5 t/m³, △ = ≤ 1.2 t/m³, - = not authorised

Equipments

Ditch Cleaning Buckets

Ditch Cleaning Buckets Machine stability per ISO 10567* (75% of tipping capacity)

Cutting width mm	Capacity ISO 7451 ¹⁾ m ³	Weight kg	Stabilizers raised			Rear blade down			Rear outriggers + front blade down			EW Stabilizers raised			EW Rear blade down			EW Rear outriggers + front blade down			
			Stick length (m)			Stick length (m)			Stick length (m)			Stick length (m)			Stick length (m)			Stick length (m)			
			2.25	2.45	2.65	2.25	2.45	2.65	2.25	2.45	2.65	2.25	2.45	2.65	2.25	2.45	2.65	2.25	2.45	2.65	
Two-piece boom 5.05 m																					
1,500 ³⁾	0.50	370	■	■	■	■	■	■	■	■	■	■	■	■	■	■	■	■	■	■	
1,600 ²⁾	0.55	650	■	■	■	■	■	■	■	■	■	■	■	■	■	■	■	■	■	■	
1,600 ²⁾	0.80	780	■	△	△	■	■	■	■	■	■	■	■	■	■	■	■	■	■	■	
2,000 ²⁾	0.50	670	■	■	■	■	■	■	■	■	■	■	■	■	■	■	■	■	■	■	
2,000 ³⁾	0.48	360	■	■	■	■	■	■	■	■	■	■	■	■	■	■	■	■	■	■	
2,000 ²⁾	0.70	790	■	■	△	■	■	■	■	■	■	■	■	■	■	■	■	■	■	■	
Mono boom 5.00 m																					
1,500 ³⁾	0.50	370	■	■	■	■	■	■	■	■	■	■	■	■	■	■	■	■	■	■	
1,600 ²⁾	0.55	650	■	■	■	■	■	■	■	■	■	■	■	■	■	■	■	■	■	■	
1,600 ²⁾	0.80	780	■	△	△	■	■	■	■	■	■	■	■	■	■	■	■	■	■	■	
2,000 ²⁾	0.50	670	■	■	■	■	■	■	■	■	■	■	■	■	■	■	■	■	■	■	
2,000 ³⁾	0.48	360	■	■	■	■	■	■	■	■	■	■	■	■	■	■	■	■	■	■	
2,000 ²⁾	0.70	790	■	■	■	■	■	■	■	■	■	■	■	■	■	■	■	■	■	■	
Offset two-piece boom 5.00 m																					
1,500 ³⁾	0.50	370	■	■	–	■	■	–	■	■	–	■	■	–	■	■	–	■	■	–	
1,600 ²⁾	0.55	650	■	■	–	■	■	–	■	■	–	■	■	–	■	■	–	■	■	–	
1,600 ²⁾	0.80	780	■	△	–	■	△	–	■	■	–	■	△	–	■	■	–	■	■	–	
2,000 ²⁾	0.50	670	■	■	–	■	■	–	■	■	–	■	■	–	■	■	–	■	■	–	
2,000 ³⁾	0.48	360	■	■	–	■	■	–	■	■	–	■	■	–	■	■	–	■	■	–	
2,000 ²⁾	0.70	790	■	△	△	–	■	■	–	■	■	–	■	■	–	■	■	–	■	■	–
Offset mono boom 4.90 m																					
1,500 ³⁾	0.50	370	■	■	■	■	■	■	■	■	■	■	■	■	■	■	■	■	■	■	
1,600 ²⁾	0.55	650	■	■	■	■	■	■	■	■	■	■	■	■	■	■	■	■	■	■	
1,600 ²⁾	0.80	780	■	△	△	■	■	■	■	■	■	■	■	■	■	△	■	■	■	■	
2,000 ²⁾	0.50	670	■	■	■	■	■	■	■	■	■	■	■	■	■	■	■	■	■	■	
2,000 ³⁾	0.48	360	■	■	■	■	■	■	■	■	■	■	■	■	■	■	■	■	■	■	
2,000 ²⁾	0.70	790	■	■	△	■	■	■	■	■	■	■	■	■	■	■	■	■	■	■	

* Indicated loads are based on ISO 10567 and do not exceed 75% of tipping or 87% of hydraulic capacity, max. stick length without quick coupler, lifted 360° on firm with blocked oscillating axle

¹⁾ comparable with SAE (heaped)

²⁾ with 2 x 50° rotator

³⁾ rigid ditch cleaning bucket

Max. material weight ■ = ≤ 1.8 t/m³, ■ = ≤ 1.5 t/m³, △ = ≤ 1.2 t/m³, – = not authorised

Equipments

Tilt Buckets

Tilt Buckets Machine stability per ISO 10567* (75% of tipping capacity)

Cutting width mm	Capacity ISO 7451 ¹⁾ m ³	Weight kg	Stabilizers raised			Rear blade down			Rear outriggers + front blade down			EW Stabilizers raised			EW Rear blade down			EW Rear outriggers + front blade down		
			Stick length (m)			Stick length (m)			Stick length (m)			Stick length (m)			Stick length (m)			Stick length (m)		
			2.25	2.45	2.65	2.25	2.45	2.65	2.25	2.45	2.65	2.25	2.45	2.65	2.25	2.45	2.65	2.25	2.45	2.65
Two-piece boom 5.05 m																				
1,500 ²⁾	0.60	660	■	■	■	■	■	■	■	■	■	■	■	■	■	■	■	■	■	■
1,600 ²⁾	0.80	740	■	△	△	■	■	■	■	■	■	■	■	■	■	■	■	■	■	■
Mono boom 5.00 m																				
1,500 ²⁾	0.60	660	■	■	■	■	■	■	■	■	■	■	■	■	■	■	■	■	■	■
1,600 ²⁾	0.80	740	■	△	△	■	■	■	■	■	■	■	■	■	■	■	■	■	■	■
Offset two-piece boom 5.00 m																				
1,500 ²⁾	0.60	660	■	■	–	■	■	–	■	■	–	■	■	–	■	■	–	■	■	–
1,600 ²⁾	0.80	740	△	–	–	■	△	–	■	■	–	■	△	–	■	■	–	■	■	–
Offset mono boom 4.90 m																				
1,500 ²⁾	0.60	660	■	■	■	■	■	■	■	■	■	■	■	■	■	■	■	■	■	■
1,600 ²⁾	0.80	740	△	△	△	■	■	■	■	■	■	■	■	■	■	■	■	■	■	■

* Indicated loads are based on ISO 10567 and do not exceed 75% of tipping or 87% of hydraulic capacity, max. stick length without quick coupler, lifted 360° on firm with blocked oscillating axle

¹⁾ comparable with SAE (heaped)

²⁾ with 2 x 50° rotator

Max. material weight ■ = ≤ 1.8 t/m³, ■ = ≤ 1.5 t/m³, △ = ≤ 1.2 t/m³, – = not authorised

Equipment

Undercarriage

Dual-circuit braking system	•
Rear stabilizer blade	+
Rear + front stabilizer blade	+
Lighting trailer coupling	+
Trailer coupling with bolt, automatic	+
Digging brake, automatic	•
Tyres (twin tyres) Liebherr EM 22 290/90-20	+
Tyres (twin tyres) Mitas EM 22	•
Individual control outriggers	+
Travel speed levels (four)	•
Tilt function of trailer, hydraulic	+
Mudguards (rear and front)	+
Load holding valve on each stabilization cylinder	•
Powershift transmission, semiautomatic	•
Parking brake, maintenance-free	•
Rear outriggers + front stabilizer blade	+
Tyres, variants	+
Protection for piston rods, stabilizer cylinder	+
Speeder**	+
Storage compartment left – lockable	•
Storage compartment right – lockable	+
Undercarriage EW 2.75 m/9'	+
Tool equipment, extended	+

Uppercarriage

Uppercarriage rear light, 2 pieces, LED	+
Uppercarriage right side light, 1 piece, LED	+
Refuelling system with filling pump	+
Main battery switch for electrical system	•
Engine hood with gas spring	•
Amber beacon, at uppercarriage, LED double flash	+
Service doors, lockable	•

Hydraulic System

Shut-off valve between hydraulic tank and pump(s)	•
Pressure test fittings	•
Accumulator for controlled lowering of the equipment with the engine shut down	•
Hydraulic oil filter with integrated microfilter	•
Liebherr hydraulic oil from –20 °C to +40 °C	•
Liebherr hydraulic oil, biologically degradable	+
Liebherr hydraulic oil, specially for warm or cold regions	+
Bypass filter	+
Switchover high pressure circuit and tipping cylinder	+
Switchover high pressure circuit and two-piece boom	+

Diesel Engine

Fuel anti-theft device	+
Liebherr particle filter	•
Reversible fan drive, fully automatic	+
Automatic engine shut-down (time adjustable)	+
Preheating fuel	+
Preheating coolant*	+

Operator's Cab

Storage compartment	•
Stabilizer, proportional control on left joystick	•
Cab lights rear, halogen	+
Cab lights rear, LED	+
Cab lights front, halogen (above rain cover)	+
Cab lights front, halogen (under rain cover)	•
Cab lights front, LED (above rain cover)	+
Cab lights front, LED (under rain cover)	+
Exterior mirror, electrical adjustable, with heating	+
Mechanical hour meters, readable from outside the cab	•
Roof window made from impact-resistant laminated safety glass	•
Slewing gear brake Comfort, button on the left or right joystick	+
Operator's seat Standard	•
Operator's seat Comfort	+
Operator's seat Premium	+
Driving alarm (acoustic signal is emitted during travel, can be switched ON/OFF)	+
Fire extinguisher	+
Front screen made from impact-resistant laminated safety glass – not adjustable	+
Windscreen retractable (including upper part)	•
Intermittent windscreen wiper with wiper washer	•
Cruise control	•
Joystick steering	+
Automatic air conditioning	•
Fuel consumption indicator	•
Electric cooler	+
Steering wheel, wide version (cost-neutral option)	+
Steering column adjustable horizontally	•
LiDAT, vehicle fleet management	•
Positioning swing brake	+
Proportional control	•
Radio Comfort, control via display with handsfree set	+
Preparation for radio installation	•
Rain cover over front window opening	•
ROPS cab protection	•
Back-up alarm (acoustic signal is emitted traveling backward, can not be switched off)	+
Amber beacon, on cabin, LED double flash	+
All tinted windows	•
Windscreen wiper, roof	+
Windshield wiper, entire windscreen	•
Door with sliding window	•
Top guard	+
Front guard	+
Right side window and windshield made from laminated safety glass	•
Sun visor	+
Sun blind	•
Auxiliary heating, adjustable (week time switch)	+
Left control console, folding	•
Electronic immobilizer	+
Cigarette lighter	•



Equipment

Boom lights, 2 pieces, halogen	•
Boom lights, 2 pieces, LED	+
Stick lights, 2 pieces, LED	+
Travel vibration damper	+
High pressure circuit incl. unpressurised return line and Tool Control	+
Electronic lift limitation	+
Hydraulic circuit, extended	+
Load holding valve bucket cylinder	+
Load lug on stick	+
Leak oil line, additional for attachments	+
Liebherr ditch cleaning bucket	+
Liebherr quick coupler, hydraulic or mechanical	+
Liebherr tilt bucket	+
Liebherr tilt rotator	+
Liebherr sorting grab	+
Liebherr backhoe bucket	+
Liebherr tooth system	+
Liebherr clamshell grab	+
Medium pressure circuit incl. lines	+
Mono boom	+
Offset mono boom	+
Pipe fracture safety valves hoist cylinders	•
Pipe fracture safety valve stick cylinder	•
Hose quick coupling at end of stick	•
Quick coupling system LIKUFIX	+
Protection for piston rod, bucket cylinder	+
Protection for bottom side of stick	+
Tool Control, 20 attachment adjustments selectable over the display	+
Overload warning device	•
Two-piece boom	+
Offset two-piece boom	+



Complete Machine

Lubrication	
Lubrication undercarriage, manually – decentralised (grease points)	•
Lubrication undercarriage, manually – centralised (one grease point)	+
Central lubrication system for uppercarriage and equipment, automatically (without quick coupler and connecting link) *	•
Central lubrication system, extension for quick coupler	+
Central lubrication system, extension for connecting link	+
Special coating	
Custom painting for attachments	+
Special coating, variants	+
Monitoring	
Rear view monitoring with camera	•
Side view monitoring with camera	•
Skyview 360° (side camera not available)	+

• = Standard, + = Option

* = country-dependent, ** = depending upon the country partially only 25 km/h permitted

Options and / or special equipments, supplied by vendors other than Liebherr, are only to be installed with the knowledge and approval of Liebherr in order to retain warranty.

The Liebherr Group of Companies



Wide Product Range

The Liebherr Group is one of the largest construction equipment manufacturers in the world. Liebherr's high-value products and services enjoy a high reputation in many other fields. The wide range includes domestic appliances, aerospace and transportation systems, machine tools and maritime cranes.

Exceptional Customer Benefit

Every product line provides a complete range of models in many different versions. With both their technical excellence and acknowledged quality, Liebherr products offer a maximum of customer benefits in practical applications.

State-of-the-art Technology

To provide consistent, top quality products, Liebherr attaches great importance to each product area, its components and core technologies. Important modules and components are developed and manufactured in-house, for instance the entire drive and control technology for construction equipment.

Worldwide and Independent

Hans Liebherr founded the Liebherr family company in 1949. Since then, the family business has steadily grown to a group of more than 130 companies with nearly 44,000 employees located on all continents. The corporate headquarters of the Group is Liebherr-International AG in Bulle, Switzerland. The Liebherr family is the sole owner of the company.

www.liebherr.com